

362XP/365/372XP

Workshop manual

101 90 61-26

CONTENTS

Introduction	1
Safety regulations	2
Symbols	3
Technical data.....	4
Service tools	6
Trouble shooting	8
Service information	10
Safety equipment	12
Recoil starter	16
Electrical system	18
Centrifugal clutch	22
Lubrication system	24
Carburettor	26
Tank unit.....	35
Anti-vibration system	37
Piston and cylinder	38
Crankcase and crankshaft	42

INTRODUCTION

General

This manual provides a detailed description of procedures for trouble shooting, repair and testing of the chainsaw. The safety precautions that should be taken during repair work are also described.

Safety

Note! The section dealing with safety should be read and understood by all who carry out repair or service work on the chainsaw.

Warning markings are shown both in this manual and on the chainsaw itself. See page 5. If a warning mark on the chainsaw has been damaged or is missing, it must be replaced immediately in order to maximise safety when the saw is in use.

Target Audience

This workshop manual is written for personnel assuming that they have general knowledge of service and repair of small engines.

The manual should be read and understood by all personnel who will carry out service and repair work on the chainsaw. The manual is also suitable for use in the training of new employees.

Changes

As production continues, changes will be introduced successively to the chainsaw. If at any time these changes influence service and/or spares, special service announcements will be sent out, which means that this manual will cease to be current with time. In order to avoid problems, the manual should always be read together with all service announcements that apply to the specific model of chainsaw.

Tools

For specific procedures special tools are required. In this workshop manual, all the service tools required are listed. Their use is described in the appropriate section.

Always use Husqvarna original:

- Spares
- Service tools
- Accessories

Arrangement

This workshop manual can be used in two different ways:

- Repair of a specific sub-assembly on the chainsaw.
- Dismantling and reassembly of the whole chainsaw.

Repair of a specific sub-assembly

When a specific sub-assembly on the chainsaw is to be repaired, proceed as follows:

1. Look up the page referring to the relevant sub-assembly.
2. Carry out the steps: Dismantling
 Cleaning and inspection
 Reassembly

Dismantling and reassembly of the entire chainsaw

When the entire chainsaw is to be dismantled and reassembled, proceed as follows:

1. Look up page 16, which deals with the **recoil starter** and carry out the instructions under the heading **Dismantling**.
2. Work forwards through the manual and carry out **Dismantling** instructions in the order that the sections occur.
3. Return to **recoil starter** on page 16 and follow the instructions under **Cleaning and inspection**.
4. Work forward through the manual and carry out **Cleaning and inspection** in the order that the sections occur.
5. Order or fetch all the required spare parts from the spares warehouse.
6. Look up page 44 which deals with **the crankcase** and carry out the instructions under **Assembly**.
7. Work backwards through the manual and carry out **Reassembly** instructions as the sections occur.

In order to improve understanding, some sections begin with a **Description** of the relevant sub-assembly.

Numbering

Location indicators for components shown in the figures are marked A, B, etc.

The figures are numbered 1, 2 etc.

The location indicators and figure numbers start again from A, 1 etc. at the beginning of each new section.

SAFETY REGULATIONS

General instructions

Workshops where chainsaws are serviced must be equipped with safety equipment in accordance with local regulations.

No one should repair the chainsaw without first having read and understood the contents of this workshop manual.

The following warning texts are to be found in this manual in certain places. The warning texts occur before the procedure to which they refer.

	WARNING! The warning text indicates a risk of personal injury if instructions are not followed.
---	---

NOTE! The warning text indicates a risk of damage to equipment if instructions are not followed.
--

Special instructions

The fuel used in the chainsaw poses the following hazards:

1. The fluid and its fumes are poisonous.
2. Can cause skin irritation.
3. Is highly inflammable.

The guide bar, chain and clutch cover (chain brake) must be assembled before the chainsaw is started, otherwise the clutch may come loose causing personal injury.

Wear ear defenders when testing the chainsaw.

Do not use the saw before it has been adjusted so that the chain is still when idling.

After testing, do not touch the silencer until it has cooled. Risk for burns.

Inadequate lubrication of the chain can result in the chain breaking, which can cause serious or life threatening injury.

Make sure that the starter recoil spring does not fly out and cause personal injury.

If the spring is tensioned when the cord pulley is removed, the spring can fly out causing personal injury.

When removing the pressure spring for the chain brake, ensure that the brake is in the on position, otherwise the spring can fly out causing personal injury.

After repair, the chain brake must be checked in accordance with the instructions on page 13.

When replacing the crankshaft bearings note that the crankcase halves are hot. Use protective gloves.

When using compressed air, the air jet should never be pointed towards the body. Air can be forced into the blood stream, which can cause fatality.

SYMBOLS

Symbols on the saw

The markings shown below are moulded into the chainsaw casing.

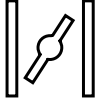

Choke

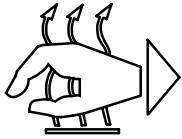

Switch for hand grip heating

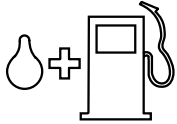

Fuel filler

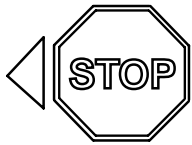

Stop button



Chain lubrication adjuster



Chain oil filler

Symbols in this manual



This symbol indicates a risk of personal injury if instructions are not followed.

TECHNICAL INFORMATION



Displacement
cm³/ cubic inch

362XP:	62,4/3,8
365:	65,1/4,0
372XP:	70,7/4,3

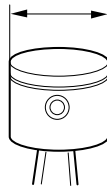

Bore
Ømm/Øinch

47/1,85
48/1,89
50/1,97

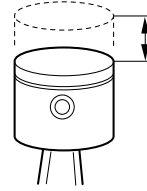

Stroke
mm/inches

36/1,42
36/1,42
36/1,42

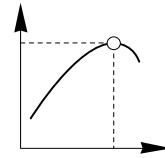

Max. power/rpm
kW/hp/ rpm

3,4/4,6/ 9 600
3,4/4,6/ 9 300
3,9/5,3/9 600

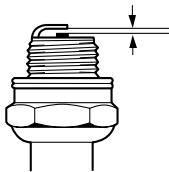

Sparkplug gap
mm/inches

362XP:	0,5/0,02
365:	0,5/0,02
372XP:	0,5/0,02

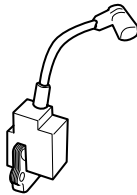

Ignition system

FHP/CD
FHP/CD
FHP/CD

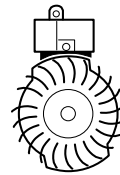

Air gap
mm/inches

0,3/0,01
0,3/0,01
0,3/0,01



Carburettor type

Walbro HD6B
Zama C3M-EL2B
Walbro HD6B

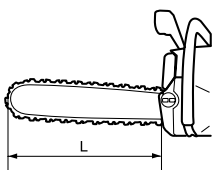

Guidebar length
cm/inches

362XP:	33-60/13-24
365:	38-61/15-24
372XP:	38-61/15-24

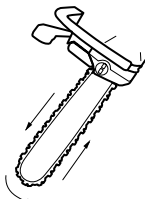

Chain speed at max. power
and 9 600 rpm
m/s

21,4
20,7
21,4

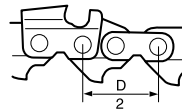

Chain pitch
mm/inches

8,25/ 0,325 9,52/ 3/8
9,52/ 3/8
9,52/3/8

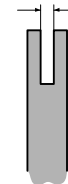

Drive link gauge
mm/inches

1,5/0,058
1,5/0,058
1,5/0,058

TECHNICAL INFORMATION

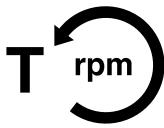

Idling speed
rpm

362XP:	2 700
365:	2 700
372XP:	2 700

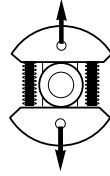

Engagement speed
rpm

3 500
3 500
3 500

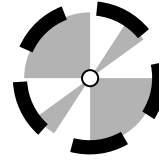

Max. overspeed
rpm

13 500
12 500
13 500

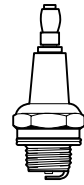

Spark plug

Champion RCJ 7Y
Champion RCJ 7Y
Champion RCJ 7Y

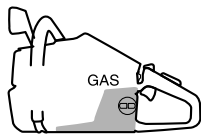

Fuel tank volume
Litres/US pints

362XP:	0,77/1,63
365:	0,77/1,63
372XP:	0,77/1,63

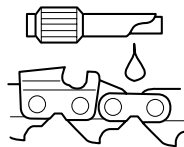

Oil pump capacity
cm³/min

4/20
4/20
4/20

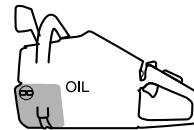

Oil tank volume
Litres/US pints

0,42/0,89
0,42/0,89
0,42/0,89

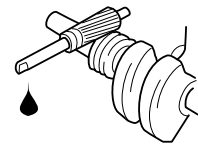

Automatic oil pump

Yes
Yes
Yes

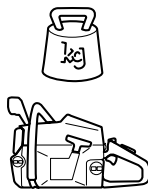

Weight without bar and chain
kg/lbs

362XP:	6,0/13,2
362XPG:	6,2/13,7
365:	6,0/13,2
372XP:	6,1/13,4
372XPG:	6,3/13,9



Weight with bar and chain
kg/lbs

15"	7,1/15,6
20"	7,5/16,5
15"	8,2/18,1
20"	8,7/19,2
15"	7,1/15,6
20"	7,5/16,5
15"	8,2/18,1
20"	8,7/19,2



Hand grip heater
Watts/rpm

65/ 10 000
65/ 10 000
–
65/10 000
65/10 000

SERVICE TOOLS

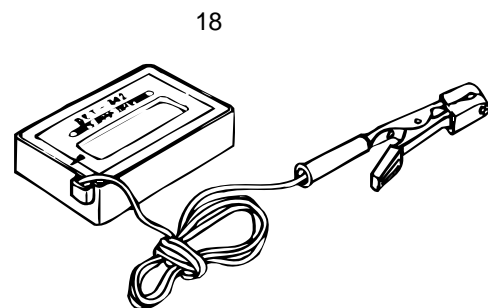
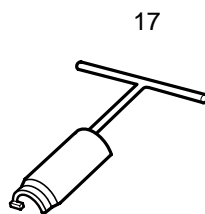
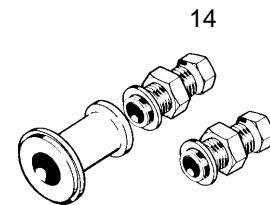
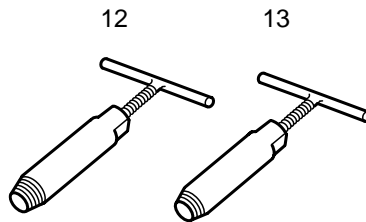
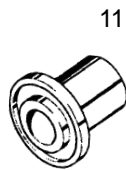
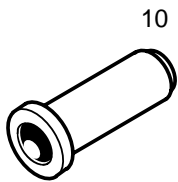
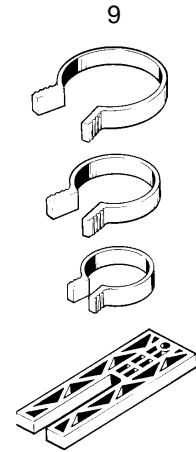
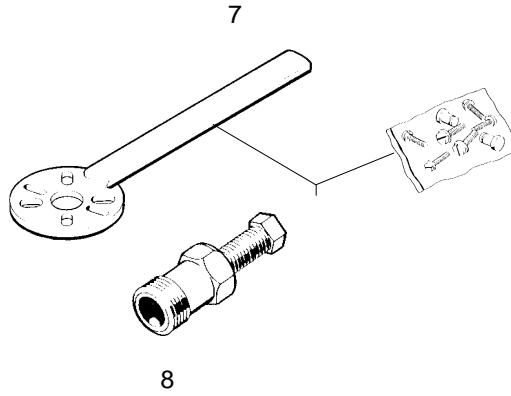
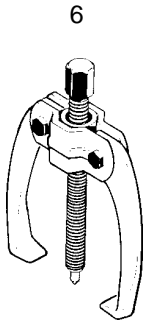
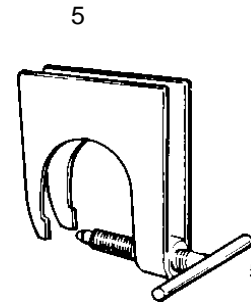
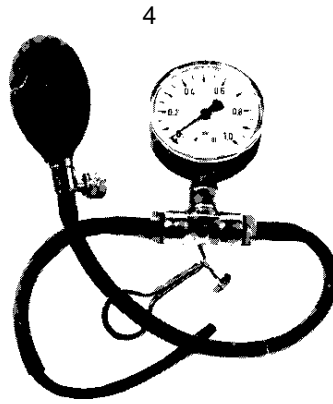
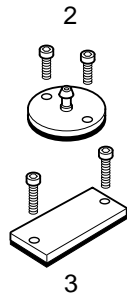
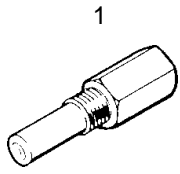

SERVICE TOOLS

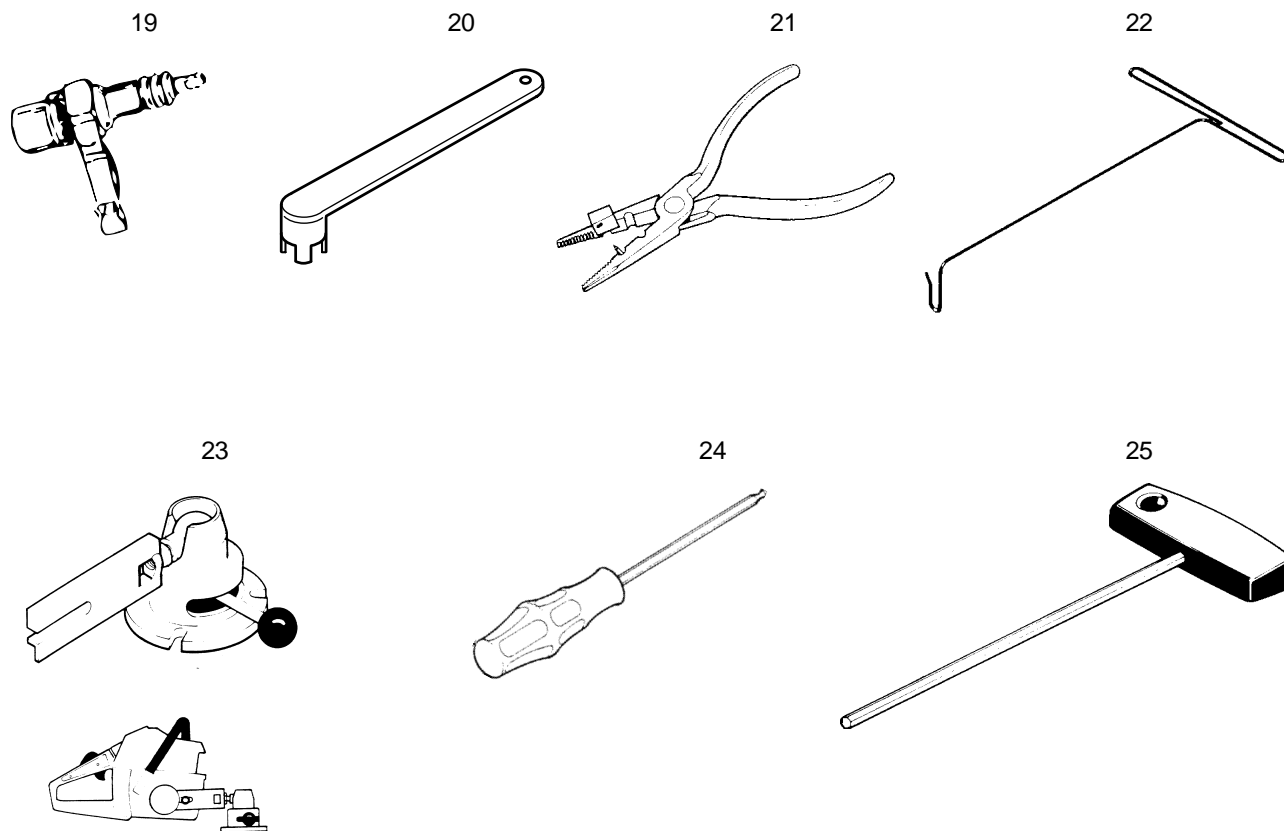

The tools listed here are the service tools required for this model of chainsaw. In addition to these tools, a normal kit of hand tools is required.

Item	Name	Usage	Ordering No.
1	Piston stop	Locking the crankshaft	502 50 33-01
2	Cover plate: crankcase inlet	Sealing off inlet	502 54 05-01
3	Cover plate: exhaust	Sealing off exhaust outlet	502 71 39-01
4	Pressure tester	Pressurising for pressure testing	502 50 38-01
5	Extractor	Removing crankshaft	502 51 61-01
6	Puller	Removing bearings from the crankshaft	504 90 90-01
7	Holding tool	Flywheel removal	502 51 49-01
8	Puller	Flywheel removal	502 50 26-01
9	Piston ring clamp	Fitting the piston	502 50 70-01
10	Oil seal driver	Inserting clutch side oil seal	502 52 21-01
11	Oil seal driver	Inserting flywheel side oil seal	502 52 20-01
12	Extractor	Removing clutch side crankcase seal	502 50 55-01
13	Extractor	Removing flywheel side crankcase seal	504 91 40-01
14	Assembly tool	Reassembling crankshaft	502 50 30-15
15	Feeler gauge, air gap	Setting ignition unit	502 51 34-02
17	Extractor	Removing large AV-springs	502 52 18-02
18	Tachometer	Setting the carburettor	502 71 14-01
19	Test spark plug	Testing ignition unit	502 71 13-01
20	Clutch tool	Clutch dismantling and assembly	502 52 22-01
21	Assembly pliers	Assembling spark plug guard	502 50 06-01
22	Fuel filter hook	Withdrawing the fuel filter	502 50 83-01
23	Clamp stand	Clamping the saw	502 51 02-01
24	Allen driver, 3 mm	For M4-bolts	502 50 86-01
24	Allen driver, 4 mm	For M5-bolts	502 50 87-01
25	Allen key, 3 mm	For M4-bolts	502 50 19-01
25	Allen key, 4 mm	For M5-bolts	502 50 18-01
25	Allen key, 5 mm	For M6-bolts	502 50 64-01

TROUBLE SHOOTING

Trouble shooting schematic

Faults that can develop on the chainsaw are divided into four groups as follows. In each category, possible malfunctions are shown on the left, with a list of possible faults on the right. The most probable fault is given first and so on.

Starting

Difficult starting	Adjust L-screw Air filter blocked Choke not working Worn choke pivot Worn choke butterfly Fuel filter blocked Fuel line blocked Piston ring seized Blocked impulse channel
Carburettor leaking fuel	Loose or faulty fuel pipe Hole in diaphragm Worn needle valve Needle valve assembly sticking Needle valve set too high Leak in metering system (air or fuel) Loose cover on carburettor pump side
Flooding when motor not running	Worn needle valve Needle valve set too high Needle valve assembly sticking

Idling (low rpm)

Will not idle	Adjust L-screw Leaking air intake (rubber) Loose carburettor mounting bolts Loose or faulty fuel pipe Fuel filter blocked Fuel line blocked Fuel tank ventilator blocked Throttle valve pivot stiff Throttle cable sticking Defective throttle return spring Bent throttle stop Faulty diffuser jet
Idling too rich	Adjust L-screw Worn needle valve Needle valve set too high Worn needle valve lever Leaking control diaphragm/cover plate Needle valve assembly sticking

Idling (low rpm) (cont.)

Idles when L-screw closed	Worn needle valve Leaking control diaphragm/cover plate Needle valve assembly sticking Worn needle valve lever Faulty diffuser jet
Idling uneven	Fuel filter blocked Fuel line blocked Leaking air intake (rubber) Loose carburettor mounting bolts Worn throttle butterfly pivot Loose throttle butterfly screw Worn throttle butterfly Needle valve assembly sticking Leak in metering system (air or fuel) Control diaphragm centre knob is worn Hole in diaphragm Leaking control diaphragm/cover plate Crankcase leaking
L-screw requires constant adjustment	Fuel line blocked Needle valve set too high Needle valve assembly sticking Leak in metering system (air or fuel) Leaking control diaphragm/cover plate Faulty diffuser jet Crankcase leaking
Too much fuel at idling	Needle valve set too high Needle valve assembly sticking Metering system damaged Worn needle valve Leaking control diaphragm/cover plate Metering system incorrectly assembled

TROUBLE SHOOTING

High rpm

Will not run at full throttle	Adjust H-screw Blocked air filter Blocked fuel tank ventilator Blocked fuel filter Fuel line blocked Loose or damaged fuel line Impulse channel leaking Impulse channel blocked Loose cover on carburettor pump side Faulty pump diaphragm Leaking air intake (rubber) Loose carburettor mounting bolts Needle valve set too low Metering system damaged Metering system incorrectly assembled Leaking control diaphragm/cover plate Needle valve assembly sticking Blocked silencer
Low power	Adjust H-screw Blocked fuel tank ventilator Blocked fuel filter Impulse channel leaking Impulse channel blocked Loose cover on carburettor pump side Faulty pump diaphragm Blocked air filter Needle valve assembly sticking Leak in metering system (air or fuel) Metering system incorrectly assembled Loose diaphragm Hole in diaphragm Leaking control diaphragm/cover plate
Will not "four-stroke"	Blocked fuel tank ventilator Blocked fuel filter Fuel line blocked Loose or damaged fuel line Impulse channel leaking Impulse channel blocked Loose cover on carburettor pump side Faulty pump diaphragm Leaking air intake (rubber) Loose carburettor mounting bolts Needle valve set too low Leak in metering system (air or fuel) Metering unit incorrectly assembled Loose diaphragm Hole in diaphragm Leaking control diaphragm/cover plate

Acceleration and retardation

Does not accelerate Adjust L-screw	Adjust H-screw Blocked air filter Blocked fuel tank ventilator Blocked fuel filter Fuel line blocked Loose or damaged fuel line Impulse channel blocked Loose cover on carburettor pump side Faulty pump diaphragm Leaking air intake (rubber) Loose carburettor mounting bolts Needle valve set too low Metering system incorrectly assembled Needle valve assembly sticking Faulty diffuser jet Blocked silencer
Motor stalls when throttle released	Adjust L-screw Adjust H-screw Faulty pump diaphragm Needle valve set too high Needle valve assembly sticking Faulty diffuser jet
Over rich acceleration	Adjust L-screw Adjust H-screw Blocked air filter Faulty pump diaphragm Faulty diffuser jet

Trouble shooting methods

In addition to faults given in the above schematic, trouble shooting can be carried out on a specific component or sub-system of the chainsaw. The different testing procedures are described in respective sections and are as follows:

1. Pressure testing the carburettor. See page 31.
2. Pressure testing the crankcase and cylinder. See page 41.
3. Pressure testing the decompression valve. See page 39.
4. Checking operation of the chain brake. See page 13.

SERVICE INFORMATION

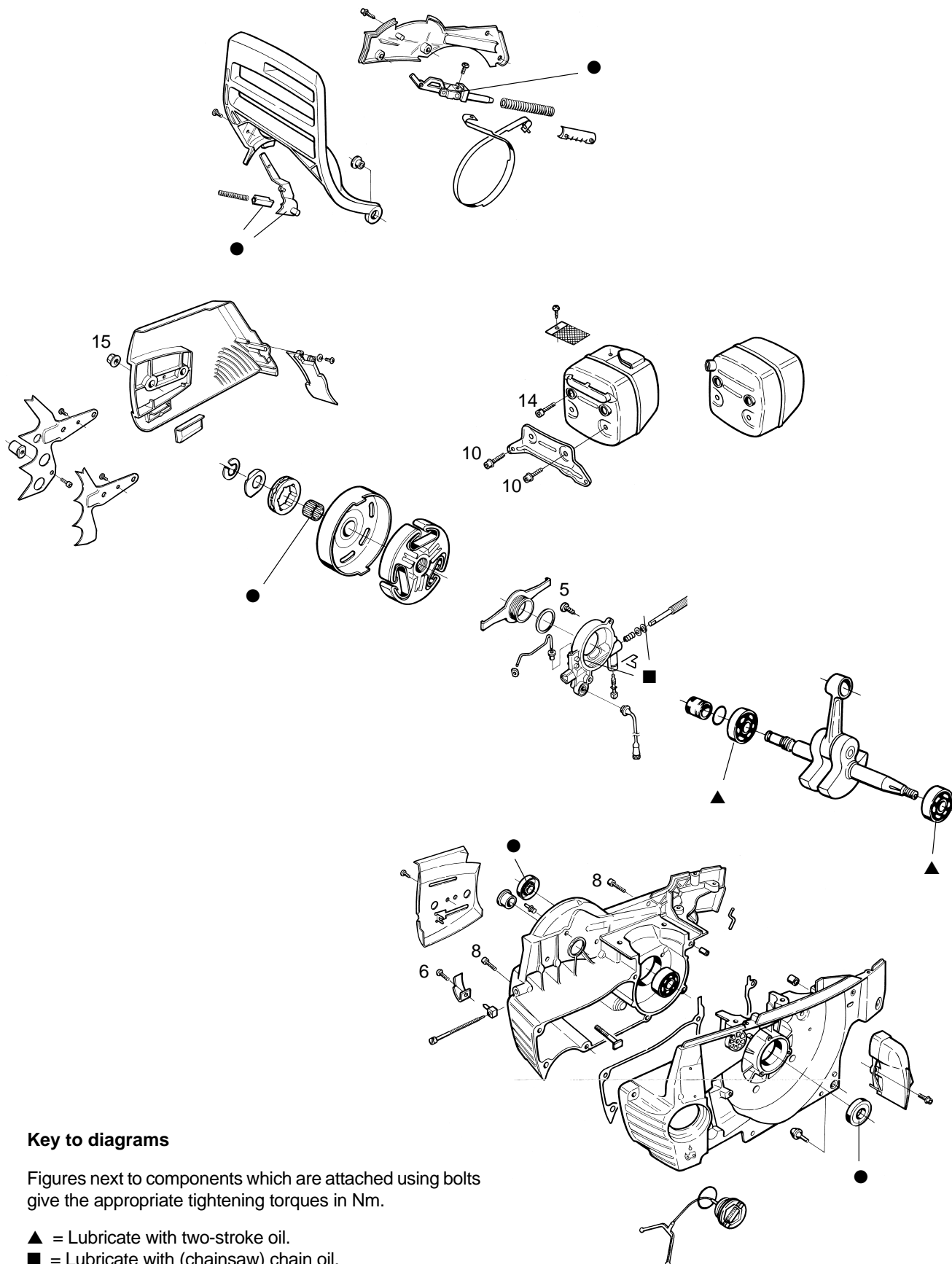

Key to diagrams

Figures next to components which are attached using bolts give the appropriate tightening torques in Nm.

- ▲ = Lubricate with two-stroke oil.
- = Lubricate with (chainsaw) chain oil.
- = Lubricate with grease.

SERVICE INFORMATION

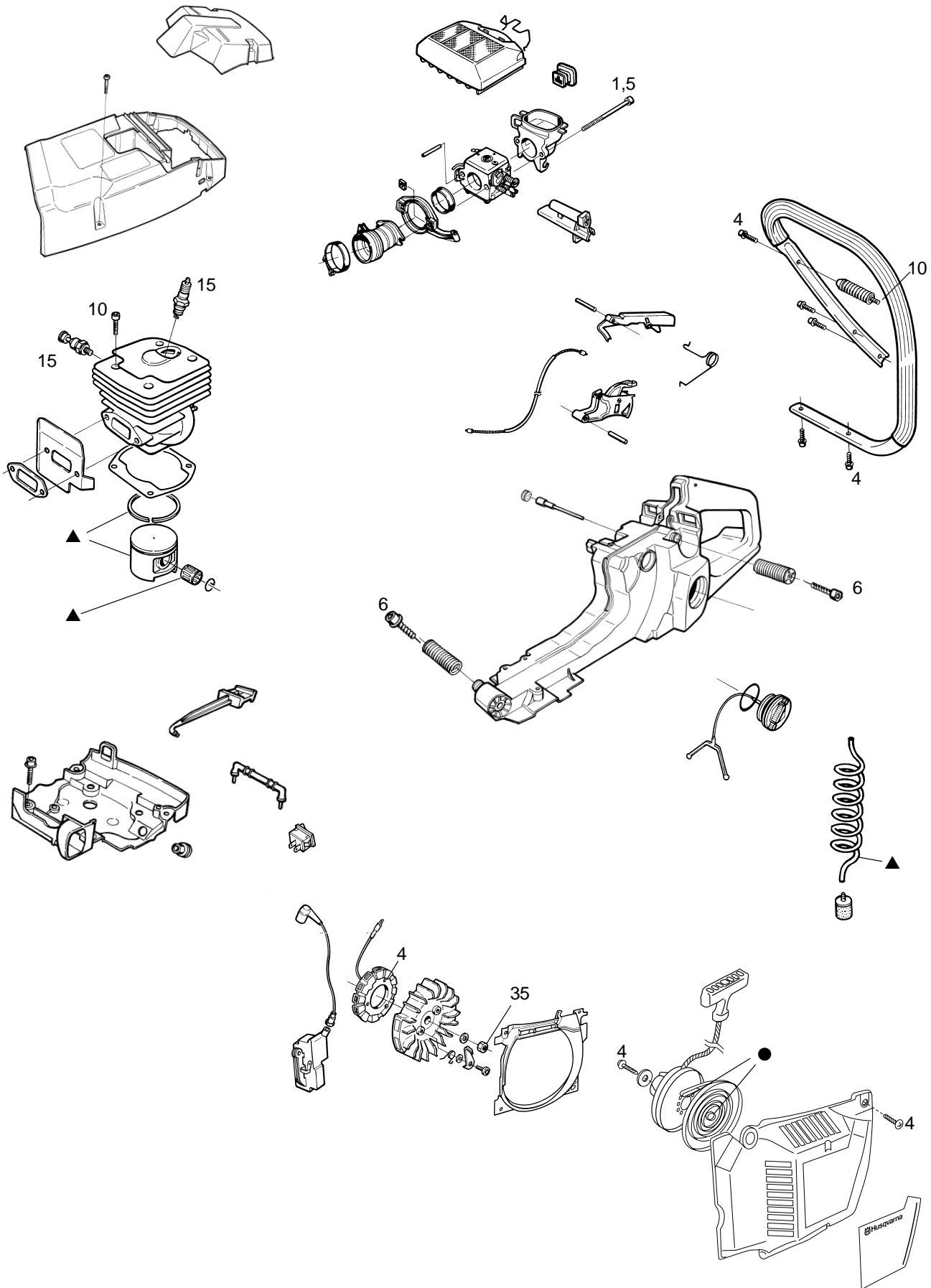



SAFETY EQUIPMENT

Chain brake

Dismantling

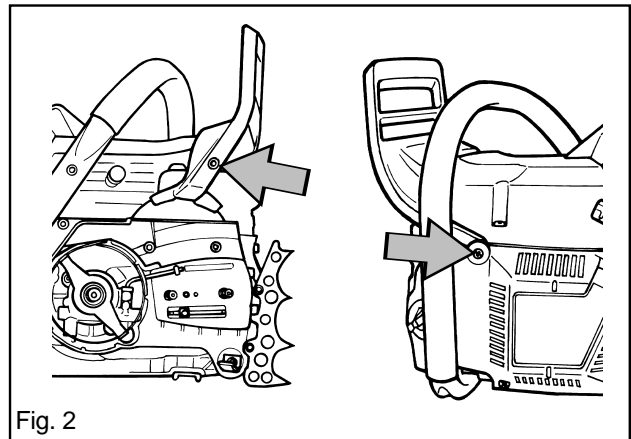
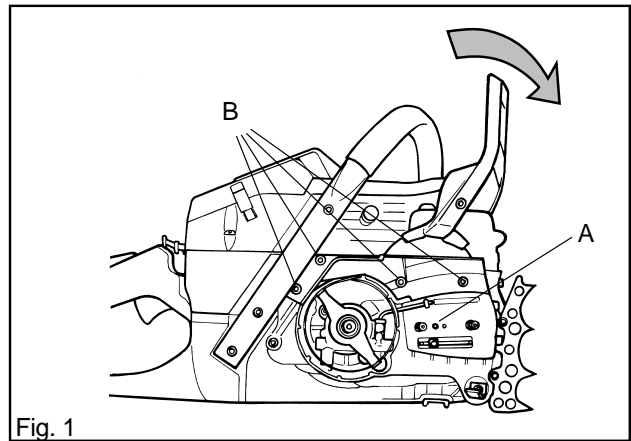
1. First remove the following components:
 - Chain and guide bar. See instruction book.
 - Centrifugal clutch. See page 22.
2. Push the hand guard forward so that the chain brake is on. See fig. 1
3. Unscrew hand guard, two bolts. Note sleeving on the starter side. See fig. 2.
4. Remove bolt (A) and chain guide-plate. See fig. 1.
5. Undo the four bolts (B) and remove the chain brake assembly cover. See fig. 1.



 **WARNING!**
Check that the chain brake is in the on position. If it is not, the pressure spring can fly up causing personal injury.

6. Press down the retaining bush (C) and remove the lever arm (D). See fig 3.
7. Remove the pressure spring by freeing the rearward end with a screwdriver. See fig 4.
8. Remove the toggle joint (E) with attached brake-strap. See fig 4.
9. Disconnect the brake-strap from the toggle joint.
10. Take out the retaining bush (C) and spring. See fig 3.

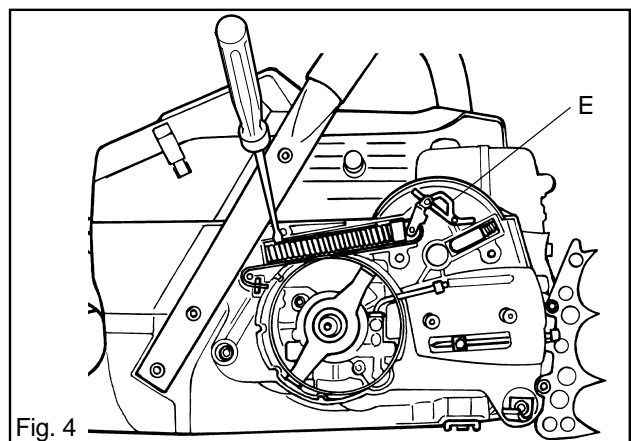
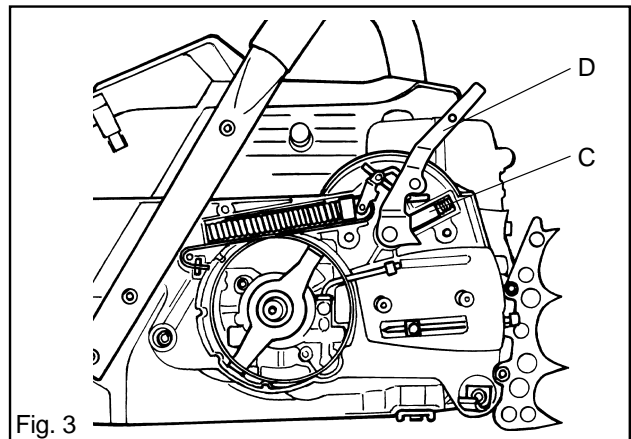

SAFETY EQUIPMENT

Inspection

Clean and inspect all components.

The brake-strap thickness must not be less than 0.8 mm at any point. See fig. 5.

Reassembly

Assemble the chain brake as follows:

1. Reattach the toggle joint and brake-strap. See fig. 5.
2. Grease the toggle joint (E) moving parts and locate the assembly in the chainsaw. See fig. 6.
3. Grease and insert the lever arm (D). See fig. 3.
4. Grease and insert the retaining bush (C) and spring. See fig. 3.
5. Locate the chain brake assembly cover, four bolts (B). Tighten the screws to 4 Nm. See fig. 1.
6. Locate the chain guide-plate with bolt (A). See fig. 1.
7. Attach the hand guard with the sleeving on the starter side. See fig. 2.
8. Draw back the hand guard so that the chain brake is in the off position.
9. Check that the brake-strap is seated correctly in the recess (F) in the crankcase. See fig. 6.
10. Assemble the following components:
 - Centrifugal clutch. See page 23.
 - Chain and guide bar. See instruction book.

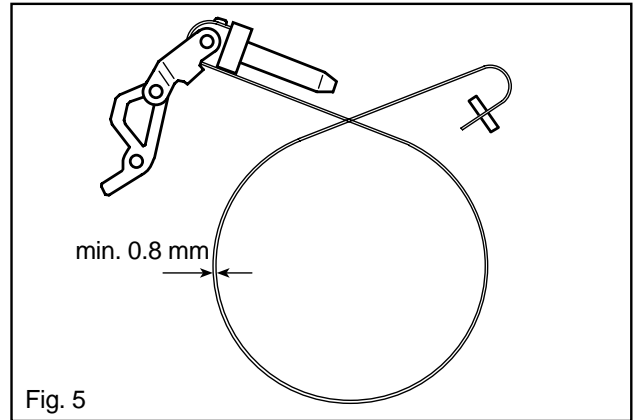

Fig. 5

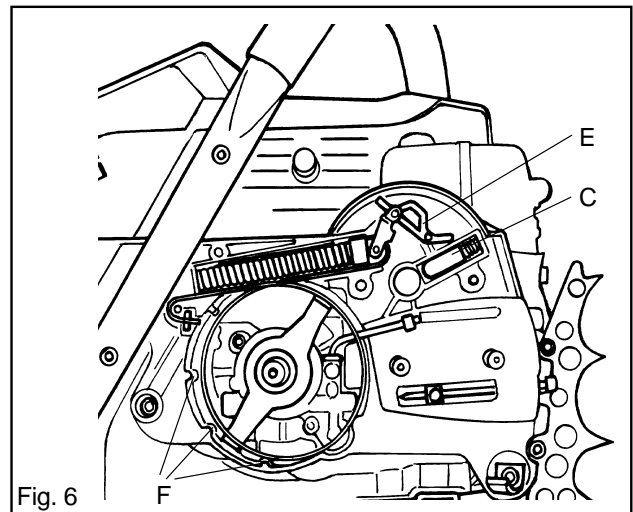

Fig. 6

Checking brake operation



WARNING!
After repair, the chain brake must be checked in accordance with the following instructions.

For this test, the motor should **not** be running.
Test the chain brake cut in as follows:

1. Hold the saw over a stable surface as shown in fig. 7. The distance between the guide bar and the surface is given in the table below.

Guide bar length, L	Height, H
15-20 inches	50 cm
21-28 inches	70 cm
29-32 inches	80 cm

2. Let go of the front hand grip and let the chainsaw pivot round on the rear hand grip.
3. When the guide bar hits the surface, the chain brake should cut in.



Fig. 7

SAFETY EQUIPMENT

Chain catcher

Remove the chain and guide bar. See instruction book.

Inspect the chain catcher and replace it if it is damaged. Tighten the retaining bolts to 6 Nm. See fig. 8.

Refit chain and guide bar. See instruction book.

Silencer



WARNING!
Do not touch the silencer before it has cooled. Risk for burns.

Dismantling

1. Remove the two M5-bolts and the two M6-bolts and lift off the silencer and silencer mount. See fig. 9.
2. Remove the gasket and cooling plate. See fig. 9.
3. If the saw is equipped with a spark guard, this should be removed. See fig. 9.

Inspection

Clean all components and check the following:

1. The spark guard is undamaged.
2. The silencer and silencer mount are not cracked or have any other defects.
3. The gasket is undamaged.

Reassembly

1. Clean the gasket, cooling plate and cylinder contact surfaces.
2. If the chainsaw is equipped with a spark guard, refit it. See fig. 9.
3. Locate the cooling plate, gasket and silencer against the cylinder. Tighten the two M6-bolts to 14 Nm. Tighten the two M5-bolts to 10 Nm.

Stop switch

Dismantling

Prise out the stop switch with the help of a screwdriver and detach the leads. See fig. 10.

Inspection

Measure the resistance by connecting an ohmmeter to the stop switch. See fig. 11. The resistance should be as follows:
"0" pressed in - less than 0.1 Ω .
"1" pressed in - more than 1000 Ω .

Reassembly

Push on the leads and press the stop switch into the slot in the tank unit.

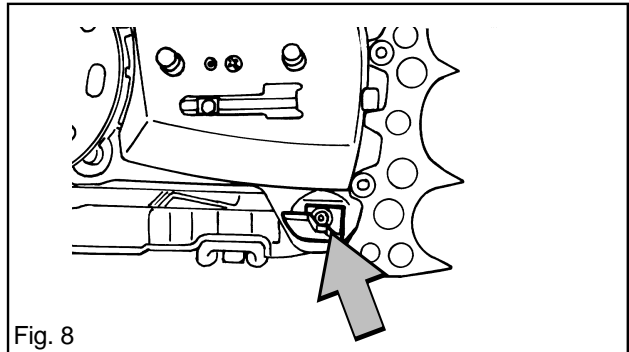

Fig. 8

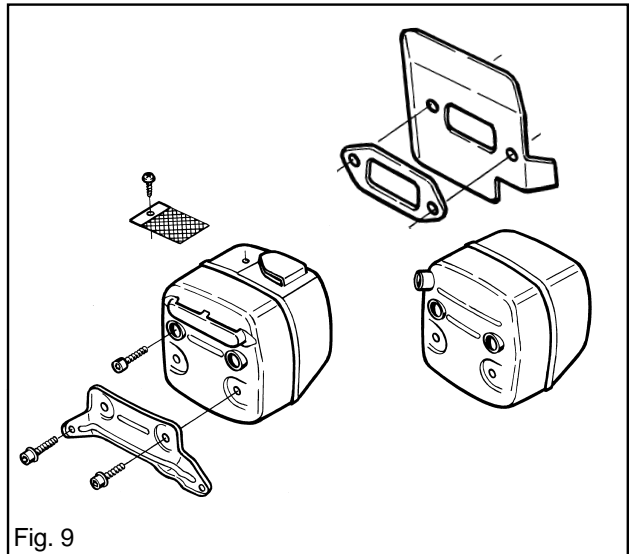

Fig. 9

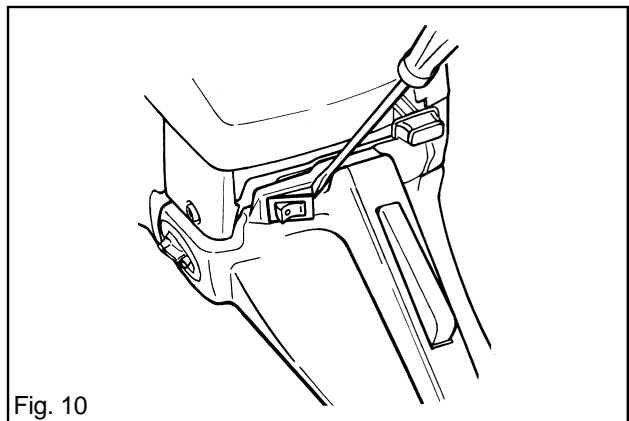

Fig. 10

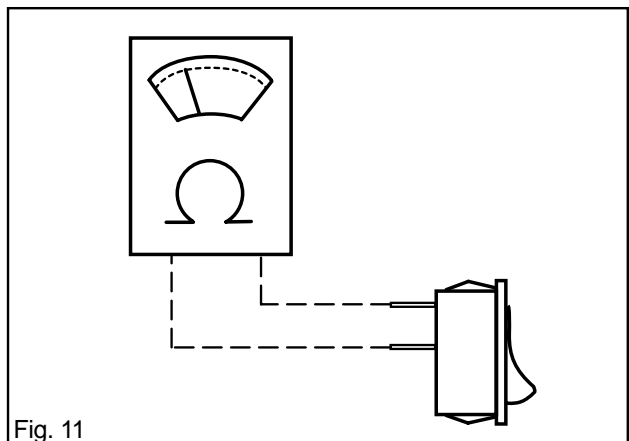

Fig. 11

SAFETY EQUIPMENT

Throttle lock

Dismantling

1. Remove the tank unit from the motor unit. See page 35.



WARNING!
The fuel that is used in the chainsaw poses the following hazards:
1. The fluid and its fumes are poisonous.
2. Can cause skin irritation.
3. Is highly inflammable.

2. Press out the throttle lock pivot (A) with the help of a driver. See fig. 12.
3. Twist the throttle lock as shown in fig. 13 and lift it out of the hand grip together with the spring.
4. Press out the throttle lever pivot (B) with the help of a driver. See fig. 12.
5. Lift out the throttle lever and cable and remove the cable.

Inspection

Clean the components and check the following:

1. The throttle cable and lever arm are undamaged and run freely.
2. The lock activation mechanism is not worn. See C in fig. 14.

Reassembly

1. Assemble the throttle lever and cable and locate them in the tank unit. Ensure that the cable lever arm (E) is between the lip (D) and the under-side of the hand grip. See fig. 15.
2. Press home the throttle lever pivot (B) with the help of a driver. See fig. 12.
3. Locate the spring in the recess in the throttle lock. Hold the spring in place and locate the throttle lock in the recess in the hand grip. See fig. 16.
4. At the same time, arrange the throttle return spring as shown in fig. 16.
5. Twist the throttle lock so that the catch (E) can pass down beside the throttle lever inside the hand grip, as shown in fig. 13.
6. Press in the throttle lock pivot (A) with the help of a driver.
7. Refit the tank unit onto the motor unit. See page 36.

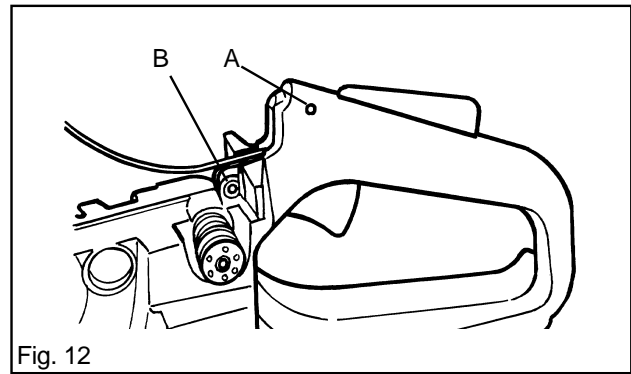

Fig. 12

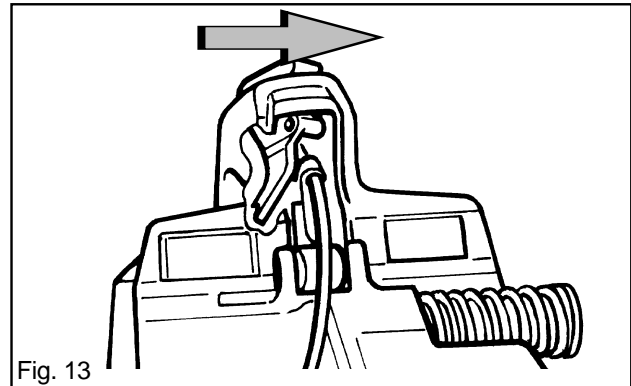

Fig. 13

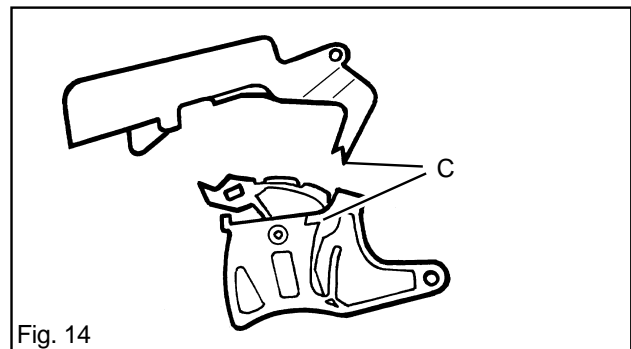

Fig. 14

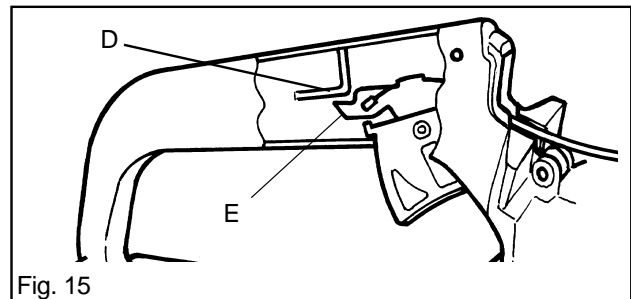

Fig. 15

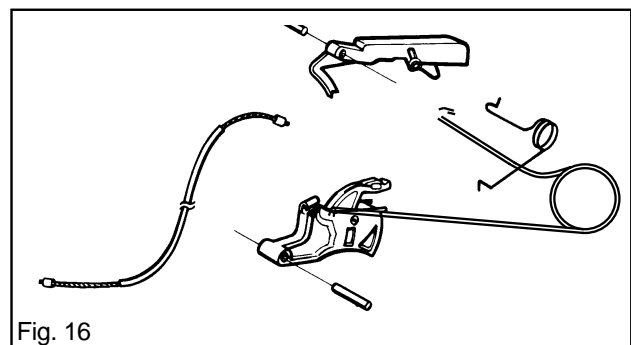

Fig. 16

RECOIL STARTER

Starter assembly

Dismantling

1. Undo the four bolts that fasten the starter assembly to the crankcase and remove it. See fig. 1.
2. Pull out the handle 20-30 cm and lift out the cord from the slot in the cord pulley. See fig. 2.
3. Turn the cord pulley anti-clockwise until there is no longer any pre-tension on the pulley.



WARNING!
If the recoil spring is tensioned when the cord pulley is removed, the spring can fly up and cause personal injury.

4. Remove the central bolt and take out the washer and cord pulley. See fig. 3.
5. If the starter cord is to be replaced, cut it off and pull out the ends from the handle and pulley with the help of pointed pliers.



WARNING!
Make sure that the recoil spring does not fly up and cause personal injury.

6. If the recoil spring is to be replaced, remove the old spring.

Cleaning and inspection



WARNING!
Make sure that the recoil spring does not fly up and cause personal injury.

Clean the components and check the following:

1. The starter cord.
2. The notches in the cord pulley.
3. That the pawls on the flywheel are undamaged, spring back towards the centre and move freely.

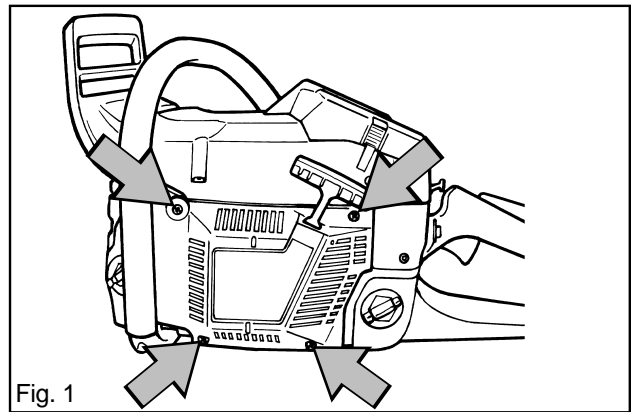

Fig. 1

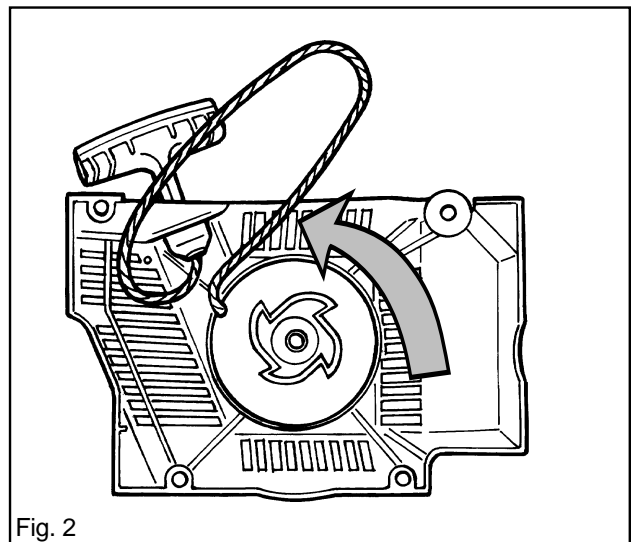

Fig. 2

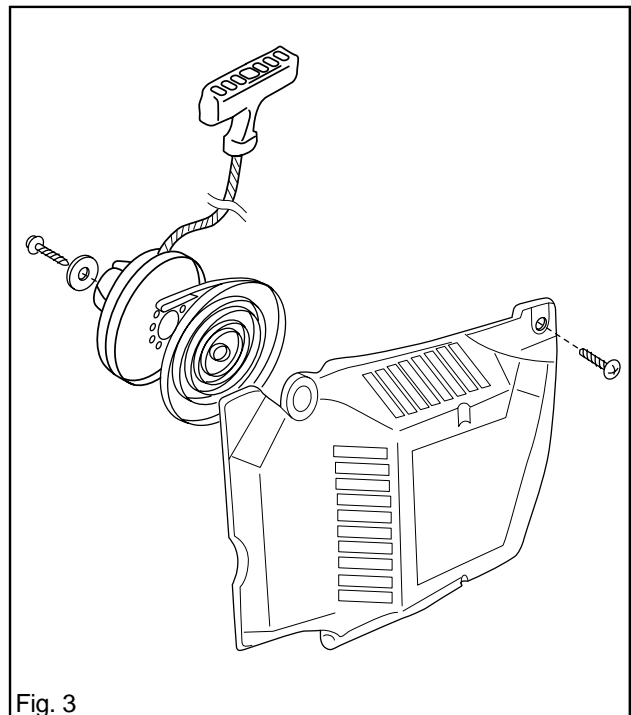

Fig. 3

RECOIL STARTER

Reassembly



WARNING!
Make sure that the recoil spring does not fly up and cause personal injury.

1. If a new recoil spring is to be used, place the new spring, with retaining wire, such that the end loop of the spring is over the peg (A) on the cord pulley. See fig. 4.
2. Press the spring into place on the pulley and remove the retaining wire.
3. If a replacement cord is to be fitted, push the free end through the hole in the cord pulley. Take hold of the end with pointed pliers inside the pulley and pull the cord through. See fig. 5.
4. Grease the cord pulley bearing and recoil spring and then fit the pulley onto the spindle. Turn the pulley gently backwards and forwards until the recoil spring catches on the stop in the housing.
5. Fit the washer and central bolt. See fig. 3. Tighten the bolt to 4 Nm.
6. Pull the cord out through the hole in the housing and attach the handle with a double knot. See fig. 5.
7. Wind the cord onto the pulley and rotate the pulley clockwise until the cord is correctly tensioned. See below and fig. 6.

Checking cord tension.

- A. Pull out the cord to its full extent.
 - B. In this position it should be possible to turn the pulley by hand a further 1/2 - 3/4 turn.
8. Refit the starter assembly onto the crankcase. Tighten the bolts to 4 Nm. See fig. 1.

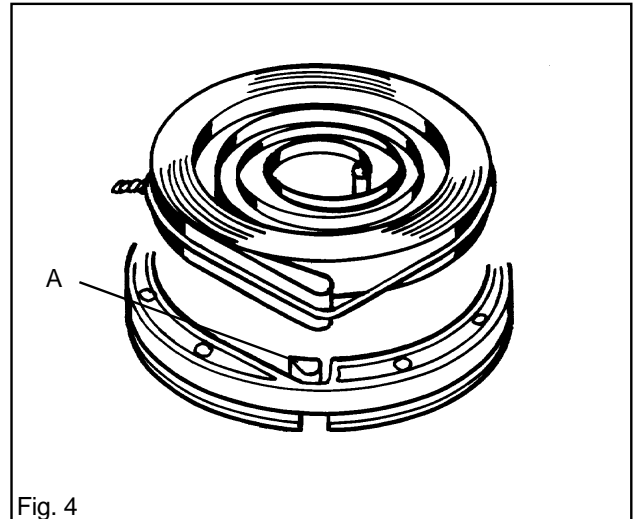

Fig. 4

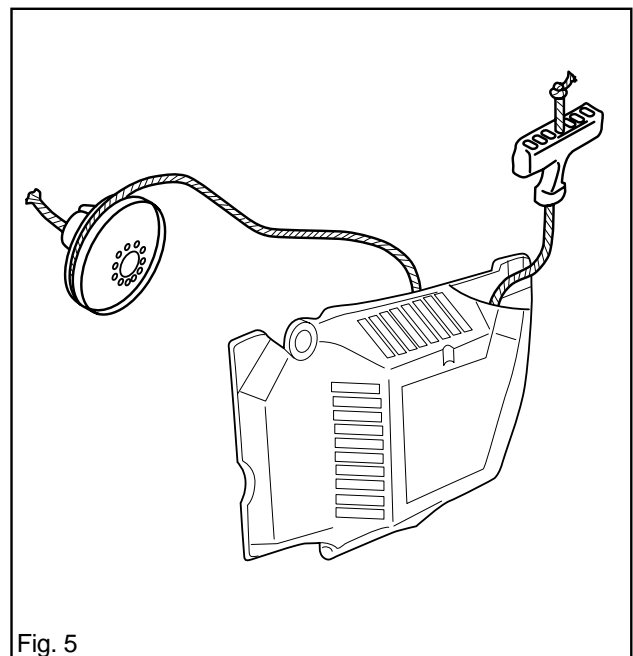

Fig. 5

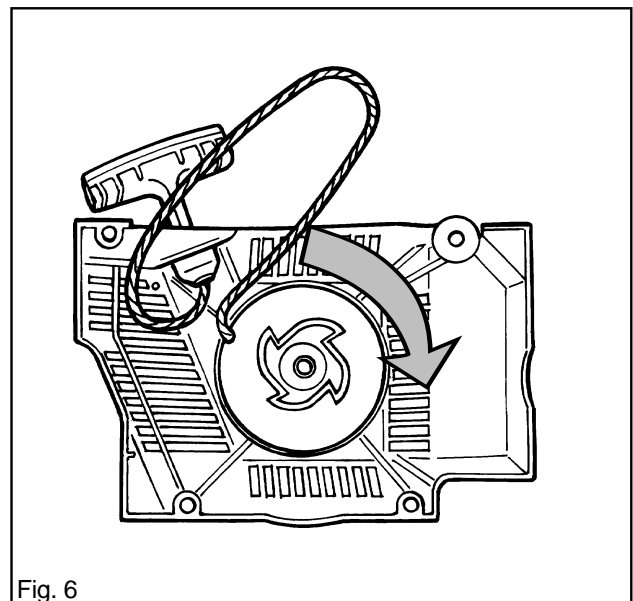

Fig. 6

ELECTRICAL SYSTEM

Ignition system

Dismantling

1. Remove the cylinder cover and starter assembly. See page 16.
2. Release the blue lead (A) (which connects to the stop switch) from the ignition module (B). See fig. 1.
3. Remove the HT lead (C) from the spark plug, release both leads from the cable guide (D) and lift out the cable guide. See fig. 1.
4. Undo the two M4-bolts and remove the ignition module (B). See fig. 1.
5. Undo and remove the two pawls (E) for the recoil starter. See fig. 1.
6. Remove the spark plug and fit the piston stop tool in the spark plug hole. See fig. 2.
7. Release the flywheel nut. Undo the nut until it is in line with the thread on the shaft outer end. See fig. 3.
8. Attach the flywheel puller. Tighten down the two M5 x 25-bolts approx. 10 turns. Tighten the central bolt, while preventing rotation with the holding tool, until the flywheel comes loose. See fig. 4.
9. Remove the puller, nut, washer and flywheel.

Cleaning and inspection

Clean all components, especially the tapers on the flywheel and shaft.
Check that the flywheel is not cracked or damaged in any other way.

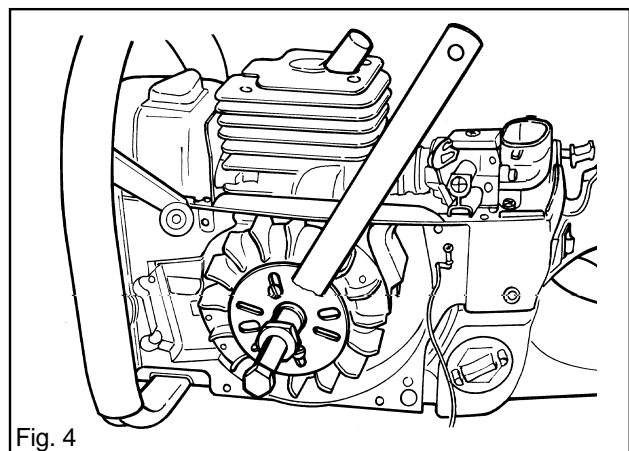
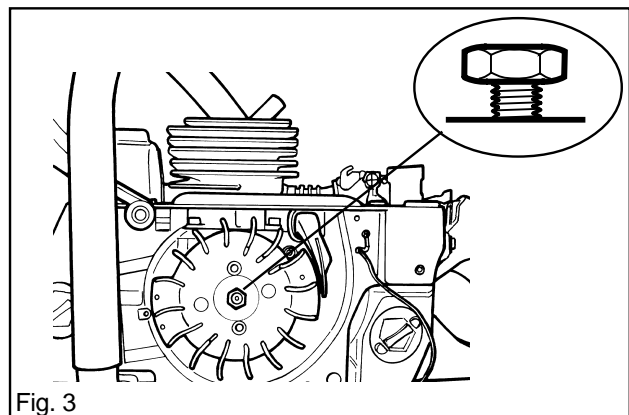
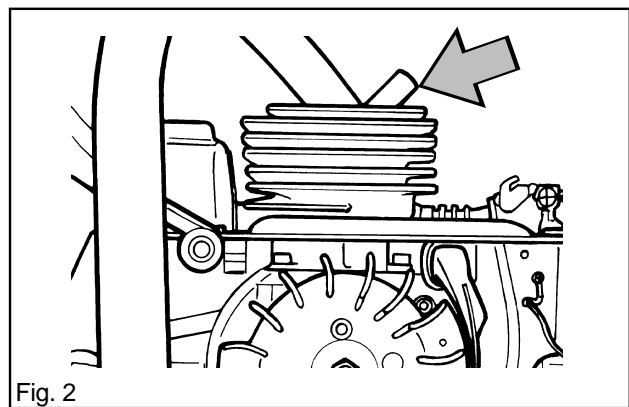
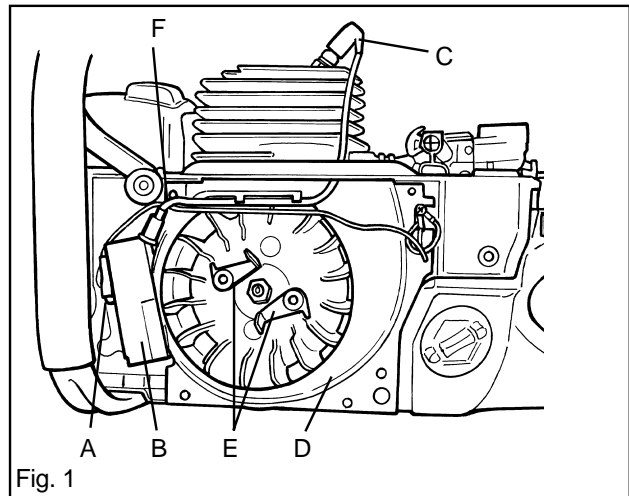

ELECTRICAL SYSTEM

Reassembly

Assemble the ignition system as follows:

1. Locate the flywheel on the crankshaft. Turn it gently until the key on the flywheel mates with the recess in the shaft.
2. Fit the flywheel washer and nut. Tighten the nut to 35 Nm. See fig. 5.
3. Locate the ignition module (B) without tightening the bolts.
4. Rotate the flywheel so that the magnet (G) is beside the ignition module. See fig. 6.
5. Insert the feeler gauge (H) (0.3 mm) into the air gap between the ignition module and flywheel magnet. The clearance applies only to the two lower pegs on the ignition module. See figs. 6 and 7.
6. Push the ignition module towards the flywheel and tighten the bolts to 4 Nm.
7. Fit the cable guide (D) and press in the HT lead into place. Remove the piston stop and connect the HT lead to the spark plug.
8. Pull out the blue lead, thread it under the HT lead at F and push home the cable clip onto the ignition module. See fig. 1.
9. Press the blue lead into the groove in the cable guide. See fig. 1.
10. Attach the pawls (E) for the recoil starter. See fig. 1.
11. Attach the cylinder cover and the recoil starter assembly. See page 17.

Stop switch

The stop switch is described in the section "Safety equipment". See page 14.

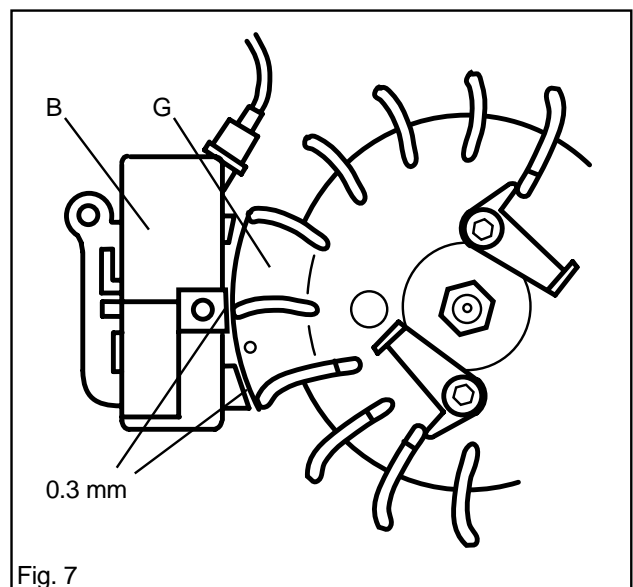
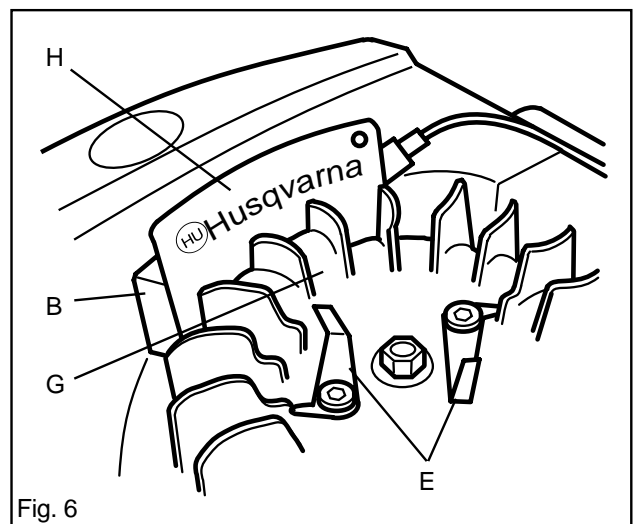
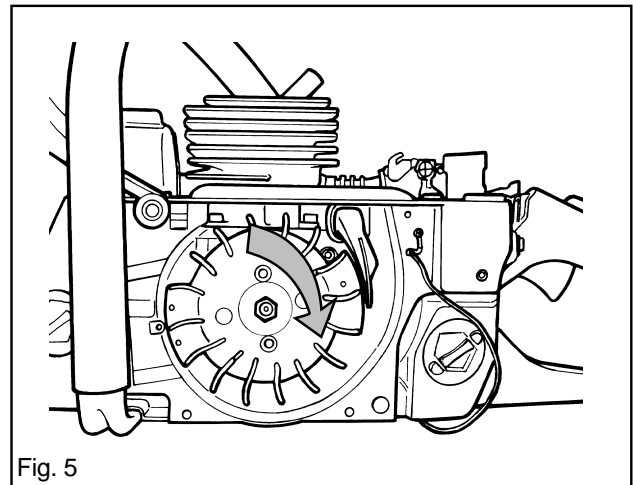

ELECTRICAL SYSTEM

Hand grip heater

Some chainsaws are equipped with hand grip heating. The hand grip heater comprises the following components.

- Generator
- On/off switch
- Heating element in the rear hand grip (tank unit).
- Front hand grip with heating element.

Trouble shooting

Trouble shooting can be carried out with most components in place on the saw. For trouble shooting an ohmmeter is required.

Carry out trouble shooting as follows:

1. Remove the cylinder cover and disconnect the connector on the red lead at A. See fig. 9.
2. Prise out the on/off switch with the help of a screwdriver. See fig. 8.
3. Switch the on/off switch to position "0".
4. Connect the ohmmeter as shown in fig. 9 and measure the resistance in the rear hand grip heating element. The meter should read 0.7 - 1.2 . If the reading is higher, replace the rear hand grip element.
5. Connect the ohmmeter as shown in fig. 10 and measure the resistance in the front handle heating element. The meter should read 3 - 4 . If the reading is higher , replace the front hand grip.
6. Connect the ohmmeter as shown in fig. 11 and measure the resistance in the generator. The ohmmeter should read between 0.9 - 1.3 . If the reading is higher or lower , replace the generator.
7. Disconnect one of the connections to the on/off switch and connect the ohmmeter as shown in fig. 12. The meter should read more than 1000 with the switch in the "0" position. The meter should read at most 0.1 when the switch is in the "1" position.
8. Reassemble the relevant components.

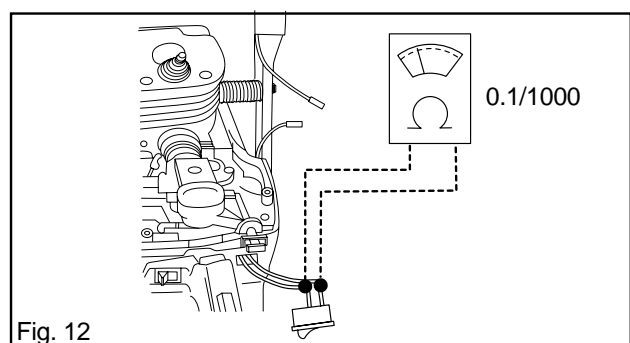
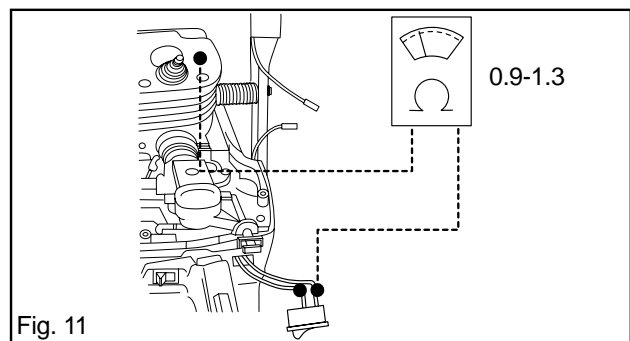
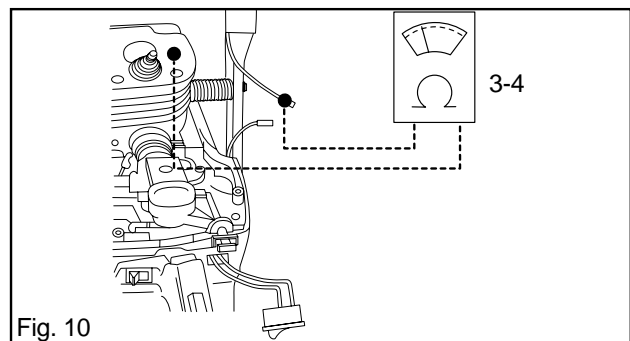
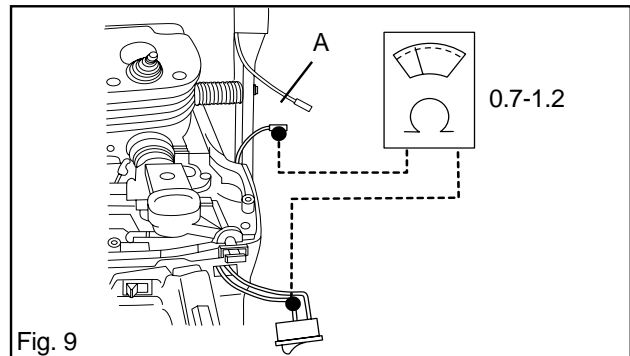
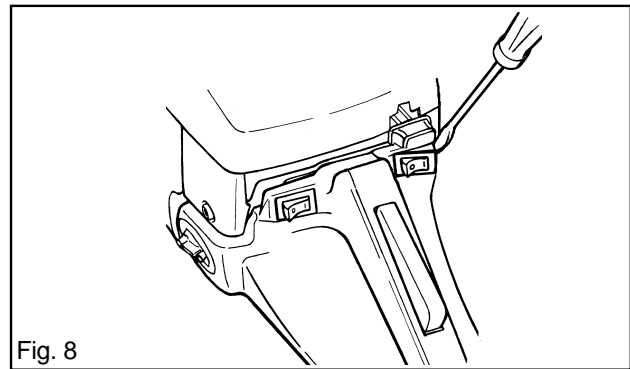

ELECTRICAL SYSTEM

Replacing the generator

1. Before the generator can be replaced, the following components must be removed:
 - A. Recoil starter. See page 16.
 - B. Flywheel. See page 18.
 - C. Silencer. See page 14.
 - D. Carburettor. See page 26.
 - E. Cylinder. See page 38.
2. Detach the carburettor space bottom plate by removing the four bolts. See fig. 13.
3. Detach the generator by removing the three fixing bolts. See fig. 14.
4. Disconnect the lead from the on/off switch and lift out the generator.
5. Locate the new generator as shown in fig. 14 and tighten the bolts to 4 Nm.
6. Position the lead as shown in fig. 15 and reconnect it to the on/off switch.
7. Fit the carburettor space bottom plate with the four bolts. See fig. 13. Ensure that the lead is seated in the recess in the plate as shown in fig. 15. Tighten the bolts to 5 Nm.
8. Refit the components from point 1.

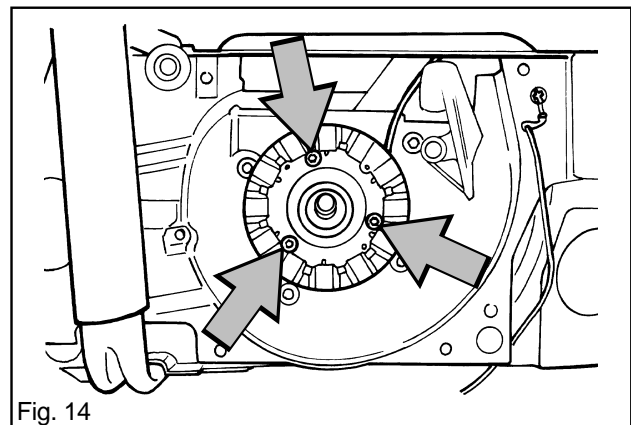
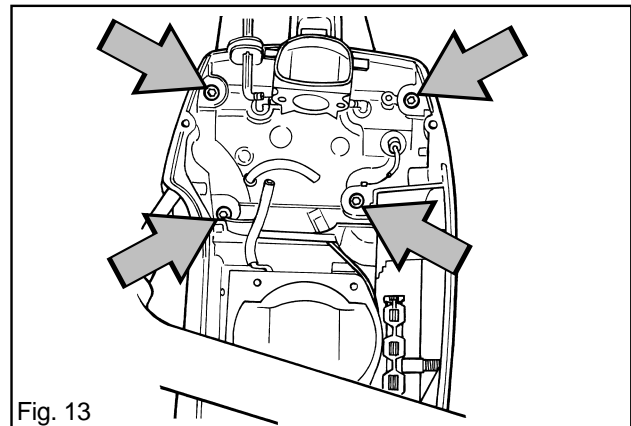

Replacing the on/off switch

1. Remove the on/off switch and disconnect the leads. See fig. 8.
2. Connect the leads to a new switch and press it into place.

Replacing the heating element in the rear hand grip (tank unit).

1. Before the rear hand grip element can be replaced the following components must be removed:
 - A. Tank unit. See page 35.
 - B. Throttle lock and throttle lever. See page 15.
2. Disconnect the leads, remove the bolts as shown in fig. 16 and remove the heating element.
3. Insert the new heating element, replace the bolts as shown in fig. 16 and reconnect the cables.
4. Refit the components from point 1.

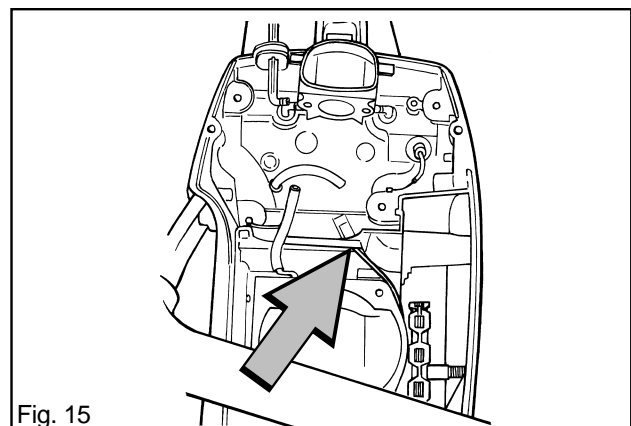

Replacing the front hand grip

1. Disconnect the two cable clips beside the springs.
2. Remove the five bolts which secure the front hand grip.
3. Fit the new hand grip and replace the five fixing bolts, tightening them to 4 Nm.
4. Reconnect the two leads.

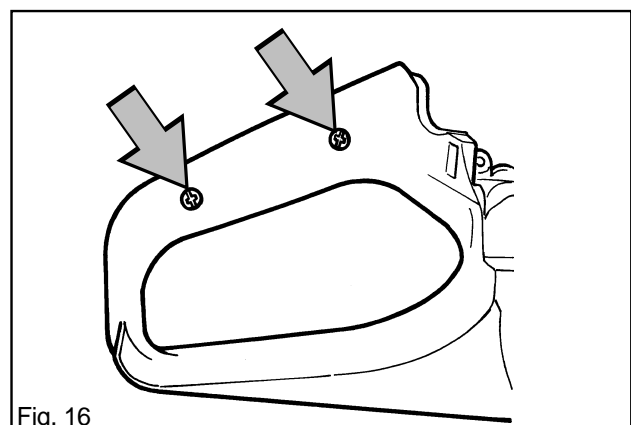

CENTRIFUGAL CLUTCH

Centrifugal clutch

Dismantling

During dismantling of the centrifugal clutch, the chain brake must be in the off position.

1. Remove the cylinder cover, chain and guide bar. See instruction book.
2. Remove the chain guide-plate by removing the bolt (A). See fig. 1.
3. Remove the circlip (B) and washer and remove the clutch drum (C), together with the needle roller bearing (D) and chain drive-wheel (E). See fig. 2.
4. Remove the spark plug, insert the piston stop tool and unscrew the clutch hub with the clutch tool. Note - left-hand thread. Turn in the direction of the arrow as shown in fig. 3.

The following points (5-7) describe the dismantling of the clutch hub.

5. Using a screwdriver, lever in the lip of the spring such that the spring sticks out a little on the other side. See fig. 4.

NOTE!

The clutch springs should not be opened out more than necessary. Risk of deformation.

6. Stretch out the springs with circlip pliers and remove them from the clutch hub.
7. Remove the clutch shoes.

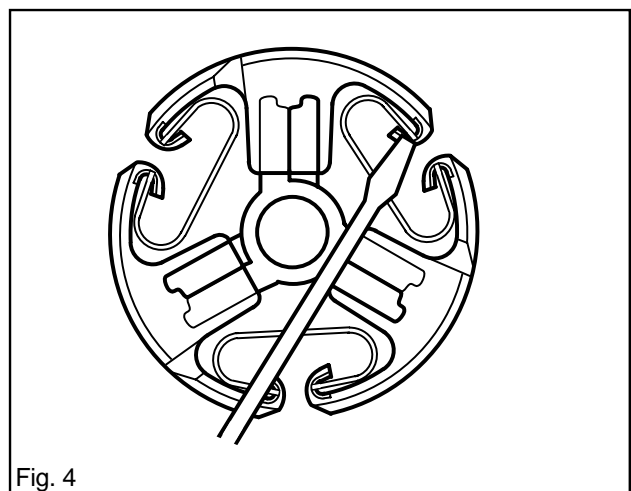
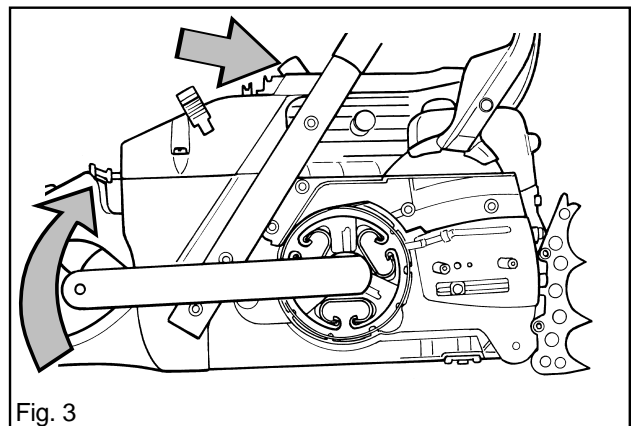
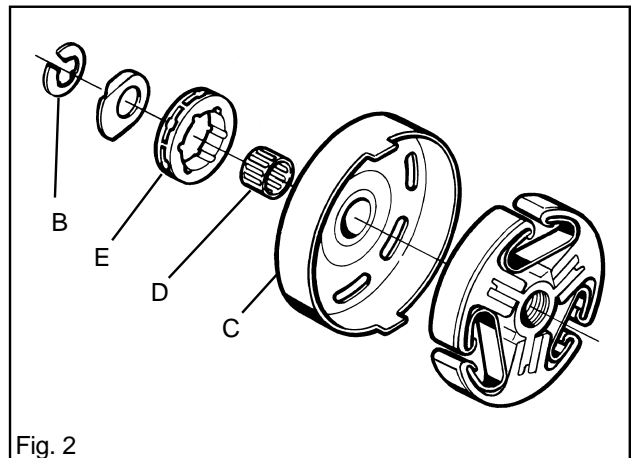
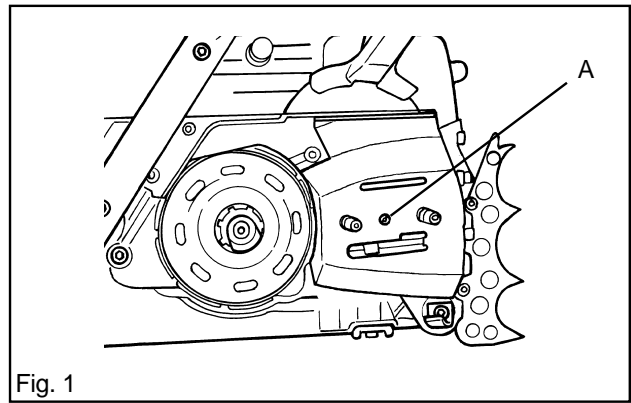

CENTRIFUGAL CLUTCH

Cleaning and inspection

Clean all components and check the following:

1. Lining thickness on the clutch shoes should not be less than 3 mm in the most worn area. See fig. 5. In order to avoid imbalance, all clutch shoes should be replaced at the same time.
2. Play between the clutch shoes and the clutch hub should not be excessive.
3. The chain drive-wheel is not worn.
4. The needle roller bearing is in good condition and the bearing surface on the crankshaft is not damaged.
5. The clutch drum friction surface and bearing surface are undamaged.

Reassembly

During reassembly of the centrifugal clutch, the chain brake should be in the off position.

NOTE!
The clutch springs should not be opened out more than necessary. Risk of deformation.

1. Locate the clutch shoes on the hub and fit the springs with the help of circlip pliers. See fig. 4.
2. Screw the clutch hub onto the crankshaft and tighten with the clutch tool. Note - left-hand thread. See fig. 6.
3. Remove the piston stop and replace the spark plug and HT lead.
4. Fit the clutch drum (C) together with the needle roller bearing (D) and chain drive-wheel (E). Grease the needle roller bearing before assembly. See fig. 2.
5. Fit the washer and circlip (B). See fig. 2.
6. Refit the cylinder cover, chain and guide bar. See instruction book.

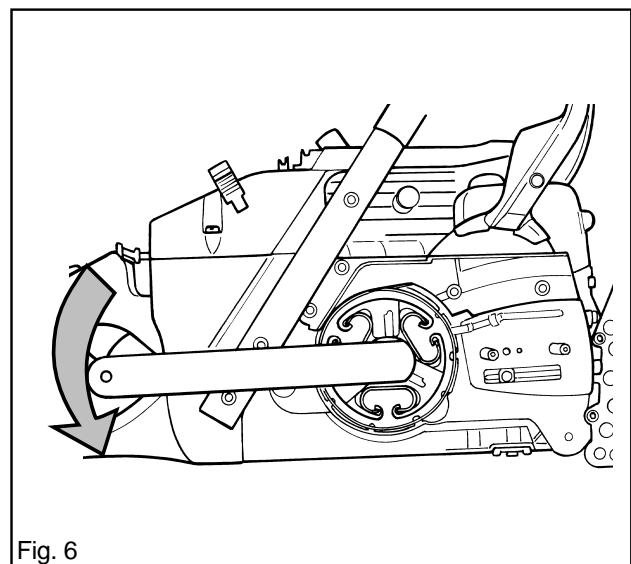
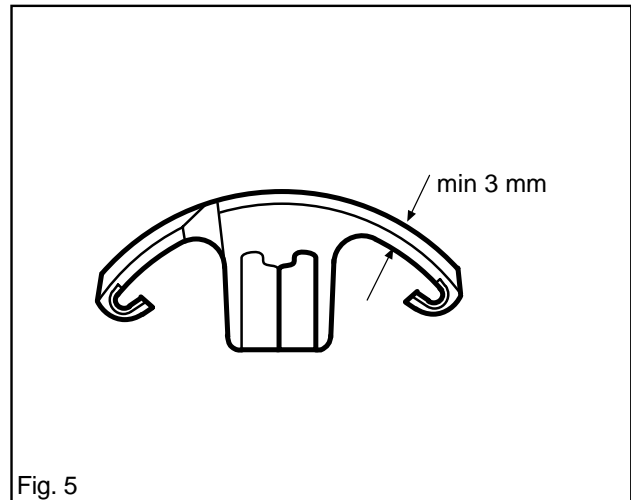

LUBRICATION SYSTEM

Lubrication system



WARNING!
Inadequate lubrication of the chain can result in the chain breaking which can cause serious or life threatening injury.

The lubrication system comprises the following components:

- Oil pump
- Suction pipe with sieve.
- Oil pipe with seals.

The above are described in sequence under the headings that follow.

Dismantling

1. Empty and clean the oil tank.
2. Remove the following components:
 - Chain and guide bar. See instruction book.
 - Centrifugal clutch. See page 22.
 - Chain brake. See page 12.
3. Unscrew the drive wheel. See fig. 1.
4. Use a screwdriver and lift the oil pipe forward at A. Lift up the pipe and pull it out of the oil pump. See fig. 2.
5. Remove the two bolts (B) and lift the oil pump from the crankcase. See fig. 2.
6. Use pointed pliers to pull free the suction pipe (C) and sieve. See fig. 3.
7. Remove the clip (D) and unscrew the adjuster screw (E). See fig 4.
8. Using pliers, press on the plug piston at F so that the cover plug (G) and piston (H) can be removed. See fig 4.
9. Using pliers, remove the spring (I) and the two washers (J). See fig. 4.

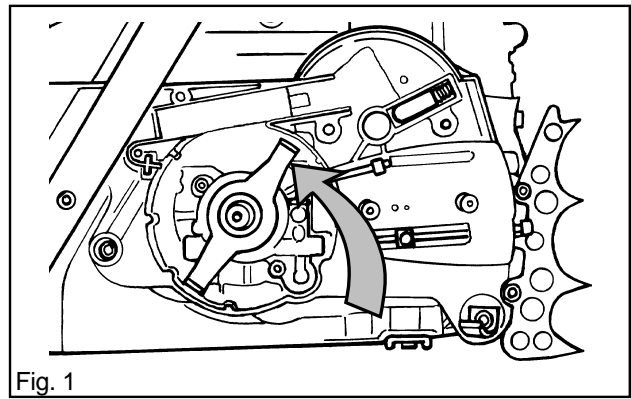

Fig. 1

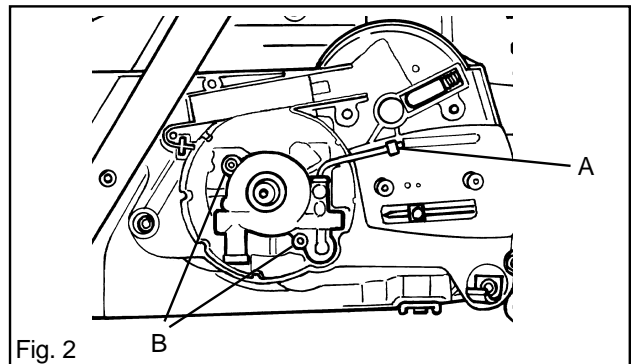

Fig. 2

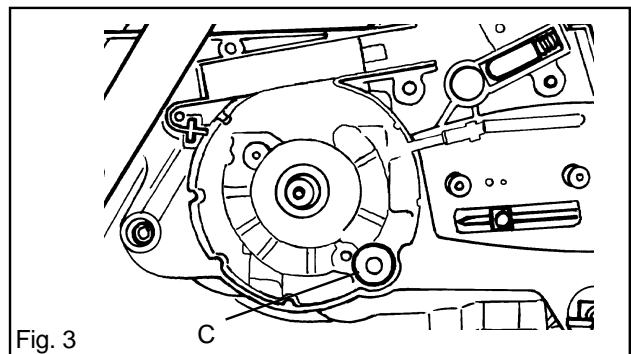

Fig. 3

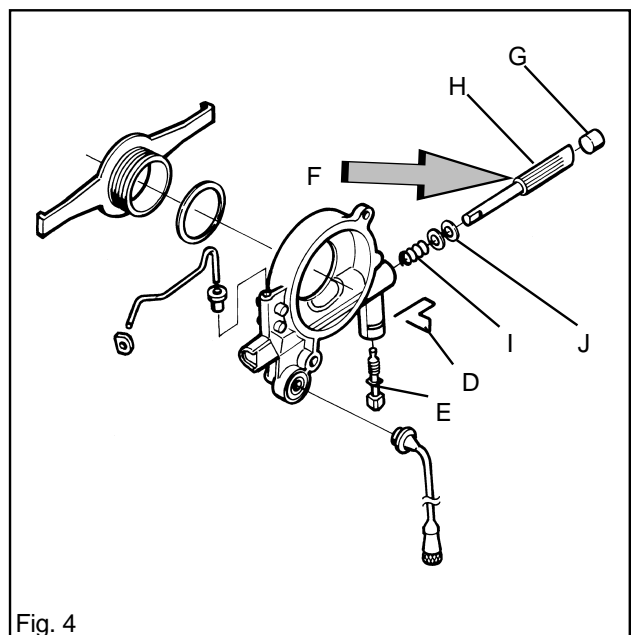

Fig. 4

LUBRICATION SYSTEM

Cleaning and inspection

Clean all components, including the pump and oil pipe mounts in the crankcase, and check the following:

1. The taper on the adjustment screw (E) does not show signs of wear. See fig. 5.
2. The pump piston (H) eccentric face does not show signs of wear. See fig. 5.
3. The pump piston pinion is undamaged. See fig. 5.
4. The oil pump drive worm gear is undamaged. See fig. 6.
5. The oil line is free from obstruction and the sieve is clean.
6. The oil pipe is free from obstruction and the seals are undamaged.

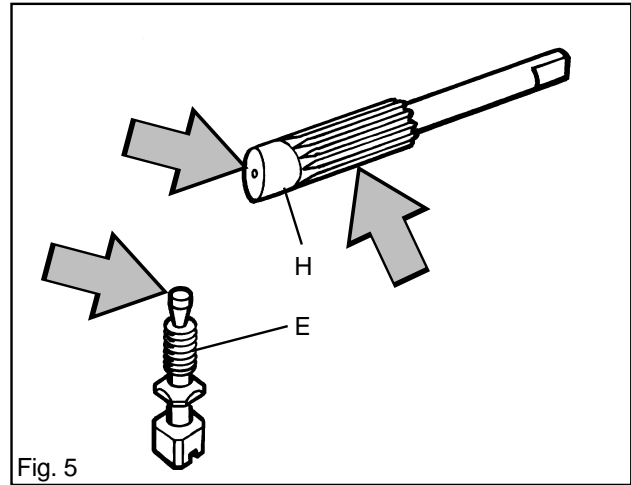

Fig. 5

Reassembly

1. Push the suction pipe (C) into the hole in the crankcase. See fig. 3.
2. Locate the spring (I), 2 washers (J) and pump piston (H) in the pump casing. Oil in all components with chain oil. See fig. 4.
3. Using a screwdriver, push in the pump piston and screw home the adjuster screw (E) fully. See fig. 4.
4. Locate the cover plug. (G). See fig. 4.
5. Fit the clip (D). See fig. 4.
6. Fit the oil pump into the crankcase. Tighten the bolts to 5 Nm. See fig. 2.
7. Locate the oil pipe and seals. See fig. 2.
8. Fit the drive wheel. See fig. 7.
9. Replace the following components:
 - Chain brake. See page 13.
 - Centrifugal clutch. See page 23.
 - Chain and guide bar. See instruction book.
10. Adjust the pump feed rate as described below.
11. Refill with chain oil and check lubrication. See instruction book.

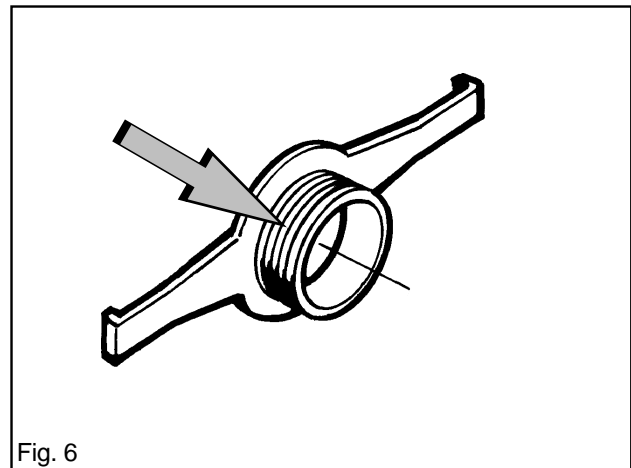

Fig. 6

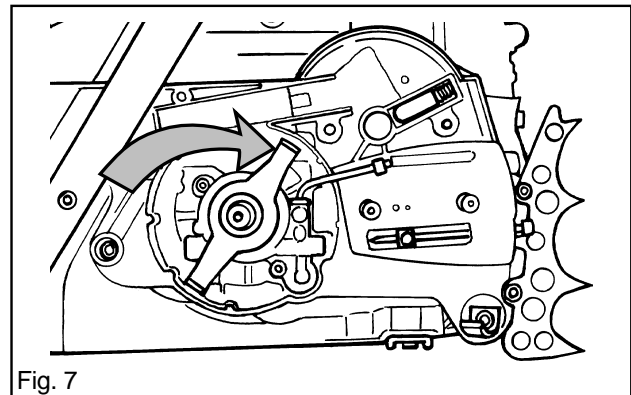

Fig. 7

Adjustment of pump feed rate

The pump feed rate is adjusted with the adjustment screw (E). The table (right) shows the number of turns outward from fully home, required for different lengths of guide bar. The table applies to Husqvarna chain oil. If another chain oil is used, the adjuster should be turned one extra turn outward in the first three cases.

Guide bar	No. of turns from fully in
-15"	1
15"-18"	2
18"-24"	3
24"-	4

CARBURETTOR

Carburettor



WARNING!
The fuel that is used in the chainsaw poses the following hazards:
1. The fluid and its fumes are poisonous.
2. Can cause skin irritation.
3. Is highly inflammable.

Description

The diagrams with this description do not show the actual carburettor on the chainsaw. They serve only to illustrate the principles of arrangement and function.

Arrangement

The carburettor comprises three sub-systems:

- Metering unit, A in fig. 1.
- Mixing venturi, B in fig 2.
- Pump unit, C in fig. 3.

The metering unit (A) contains the jets and fuel control function. It is here that the correct amount of fuel for the given engine speed and power demand is metered.

In the mixing venturi (B), the choke, throttle butterfly valve and diffuser jets are located. Air is mixed with the fuel to give a fuel/air mixture that can be ignited by the ignition spark.

In the pump unit (C), fuel is pumped from the fuel tank to the metering unit. One side of the pump diaphragm is connected to the crankcase and pulses in time with the pressure changes in the crankcase. The other side of the diaphragm pumps the fuel.

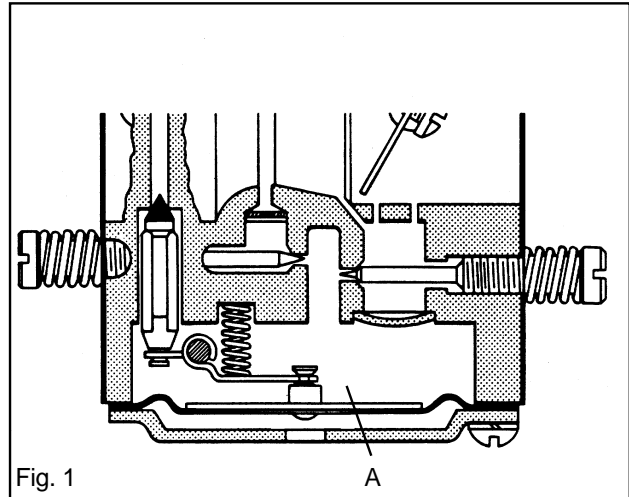

Fig. 1

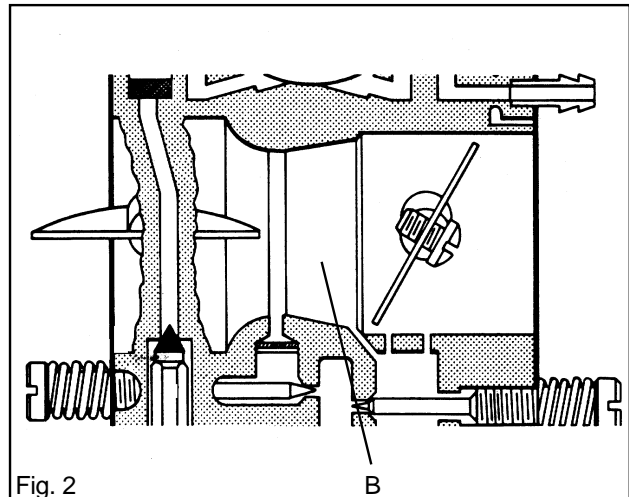

Fig. 2

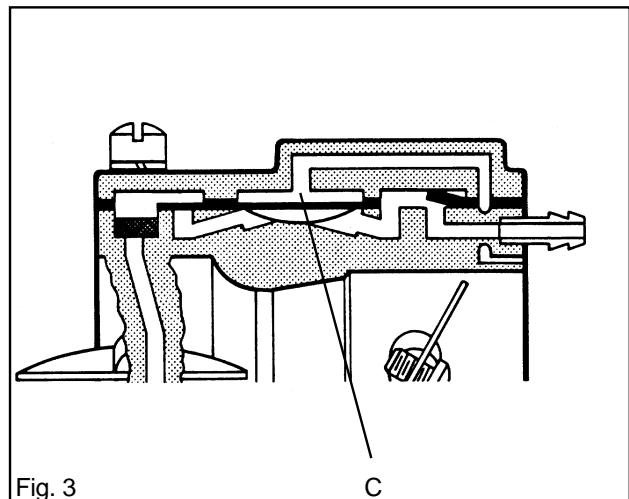

Fig. 3

CARBURETTOR

Function

The carburettor operates differently in the following operating states:

- Cold start
- Idling
- Part throttle
- Full throttle

In cold start mode (fig. 4), the choke butterfly (D) is completely closed. This increase the vacuum in the carburettor so that fuel is sucked more easily from the diffuser jets (E, F and G). The throttle butterfly (H) is partially open.

In idling mode (fig. 5) the throttle butterfly (H) is closed. Air is sucked through an aperture in the butterfly and a small amount of fuel is supplied through the diffuser jet (G).

In part throttle mode (fig. 6) the throttle butterfly (H) is partially open. Fuel is supplied through the diffuser jets (F and G).

In full throttle mode (fig. 7) both butterflies are open and fuel is supplied through all three diffuser jets (E, F and G).

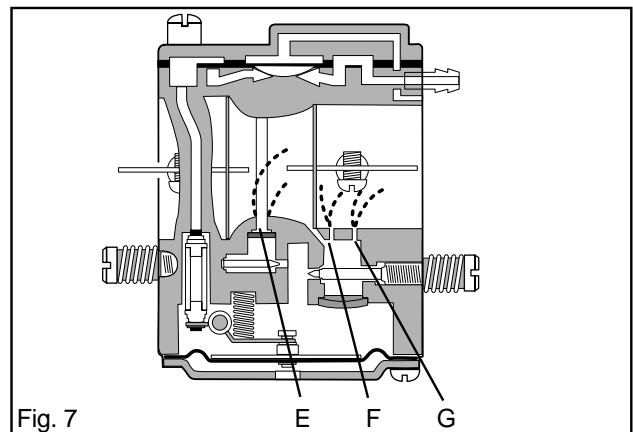
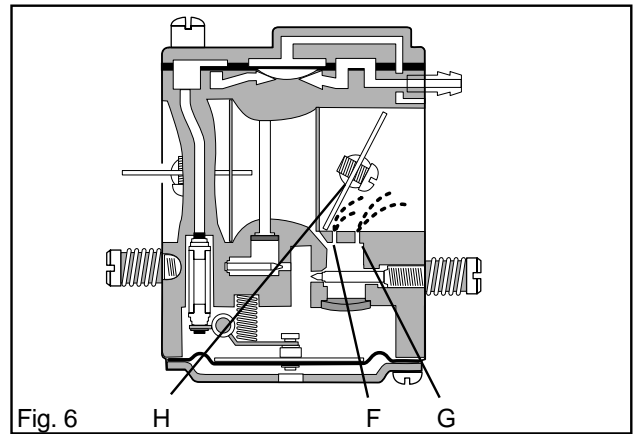
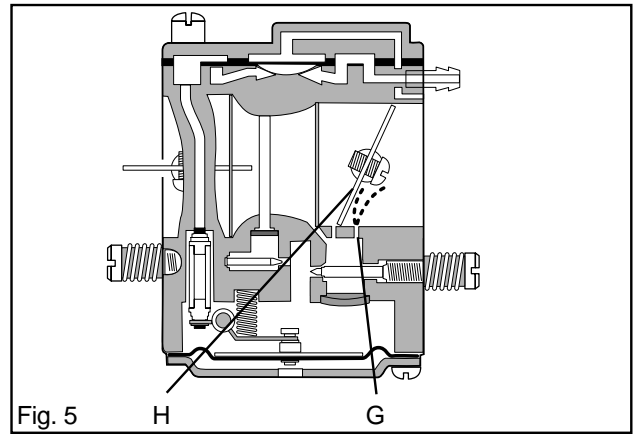
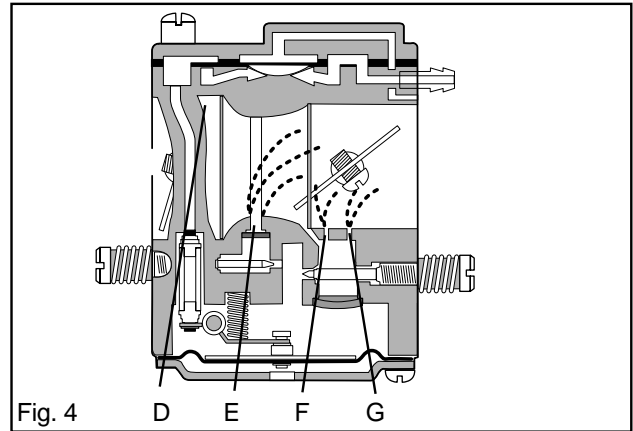

CARBURETTOR

Dismantling



WARNING!

The fuel that is used in the chainsaw poses the following hazards:

1. The fluid and its fumes are poisonous.
2. Can cause skin irritation.
3. Is highly inflammable.

Removal

See fig. 8.

1. Remove the cylinder cover and air filter. See instruction book.
2. Remove the carburettor control (A) by pushing it towards the carburettor and lifting.
3. Unhook the throttle cable and push out the choke lever.
4. Pull off the fuel pipe (B) and tube (C) to the impulse channel.
5. Remove the bolts (D) which secure the filter holder, carburettor and air intake tube. The right hand bolt can be pushed out using a welding rod or similar.
6. Loosen the air filter holder and lift off the carburettor. Leave the filter holder in the carburettor space.

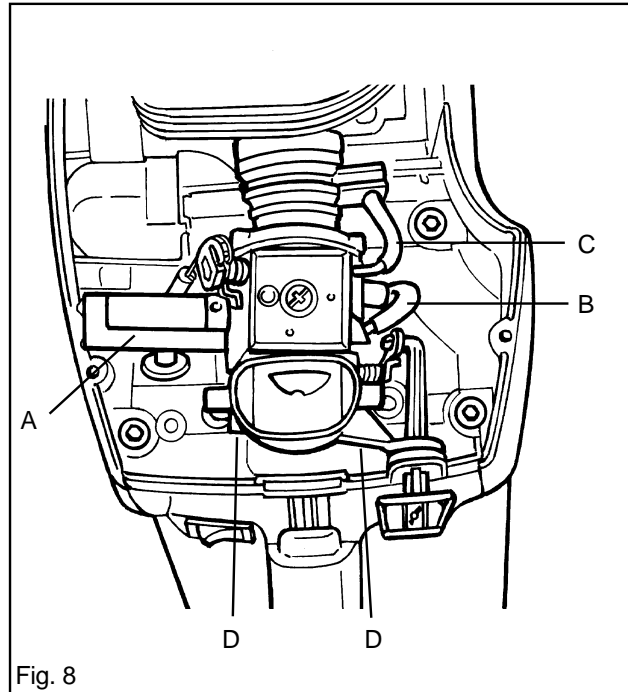

Fig. 8

Dismantling

7. Remove the top cover (E) of the metering unit and carefully remove the metering diaphragm (F) and gasket. See fig. 9.
8. Undo the screw (G) and take out the needle valve (H) together with the lever arm, spindle and spring. See fig. 9.
9. Remove the cover (I) of the pump unit and carefully remove the gasket (J) and pump diaphragm (K). See fig. 10.
10. Using a needle or similar, carefully lift out the fuel filter (L). See fig. 10.
11. Unscrew and remove the high and low speed jet screws. See fig. 12.
12. If required, unscrew the throttle and choke butterflies, and remove the spindles together with the lever arms and springs. See fig. 12.

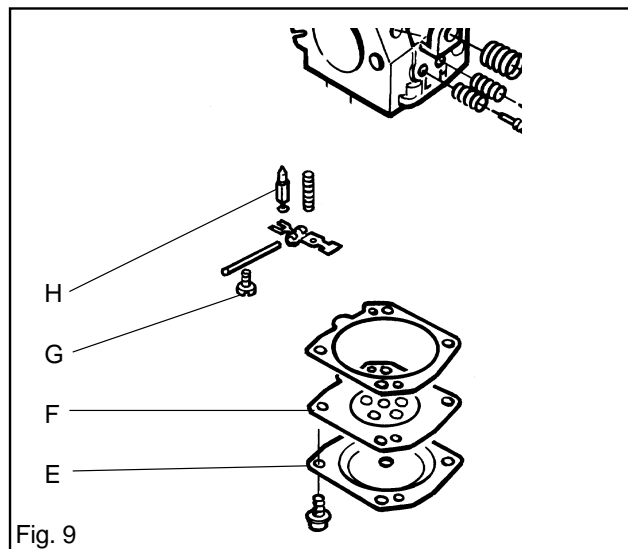

Fig. 9

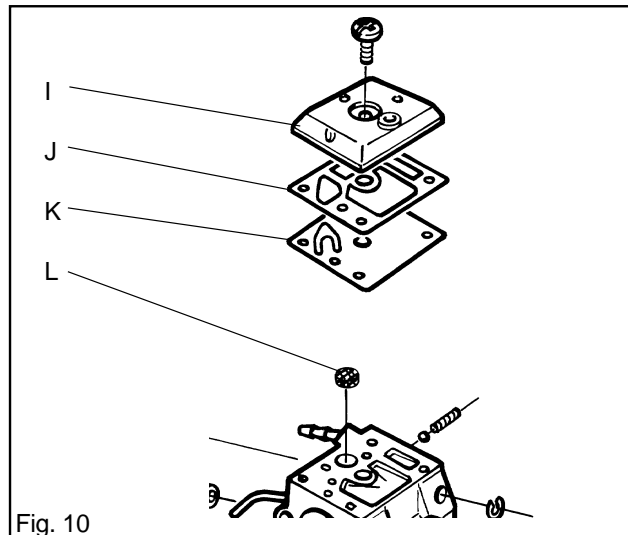

Fig. 10

CARBURETTOR

Cleaning and inspection



WARNING!
The fuel that is used in the chainsaw poses the following hazards:
1. The fluid and its fumes are poisonous.
2. Can cause skin irritation.
3. Is highly inflammable.

Clean all components in clean petrol.



WARNING!
When using compressed air, the air jet should never be pointed towards the body. Air can be forced into the blood stream which can cause fatality.

Use an air line to dry off the petrol from all components. Blow through all the channels in the carburettor body and check that they are not blocked.

See figs. 11 and 12 and check the following:

1. The gaskets, pump diaphragm and metering diaphragm are undamaged.

2. There is no play in the throttle and choke butterflies.
3. The needle valve and its lever arm are not worn at M in fig. 11.
4. The fuel filter is undamaged. See L in fig. 10.
5. The tips of the high and low speed jet screws are not damaged.
6. The air intake duct is undamaged. See pages 39 and 41.

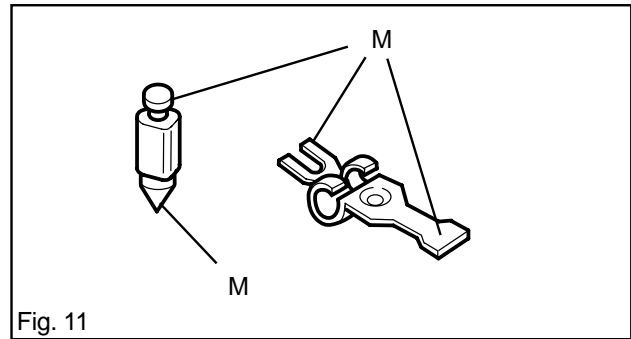

Fig. 11

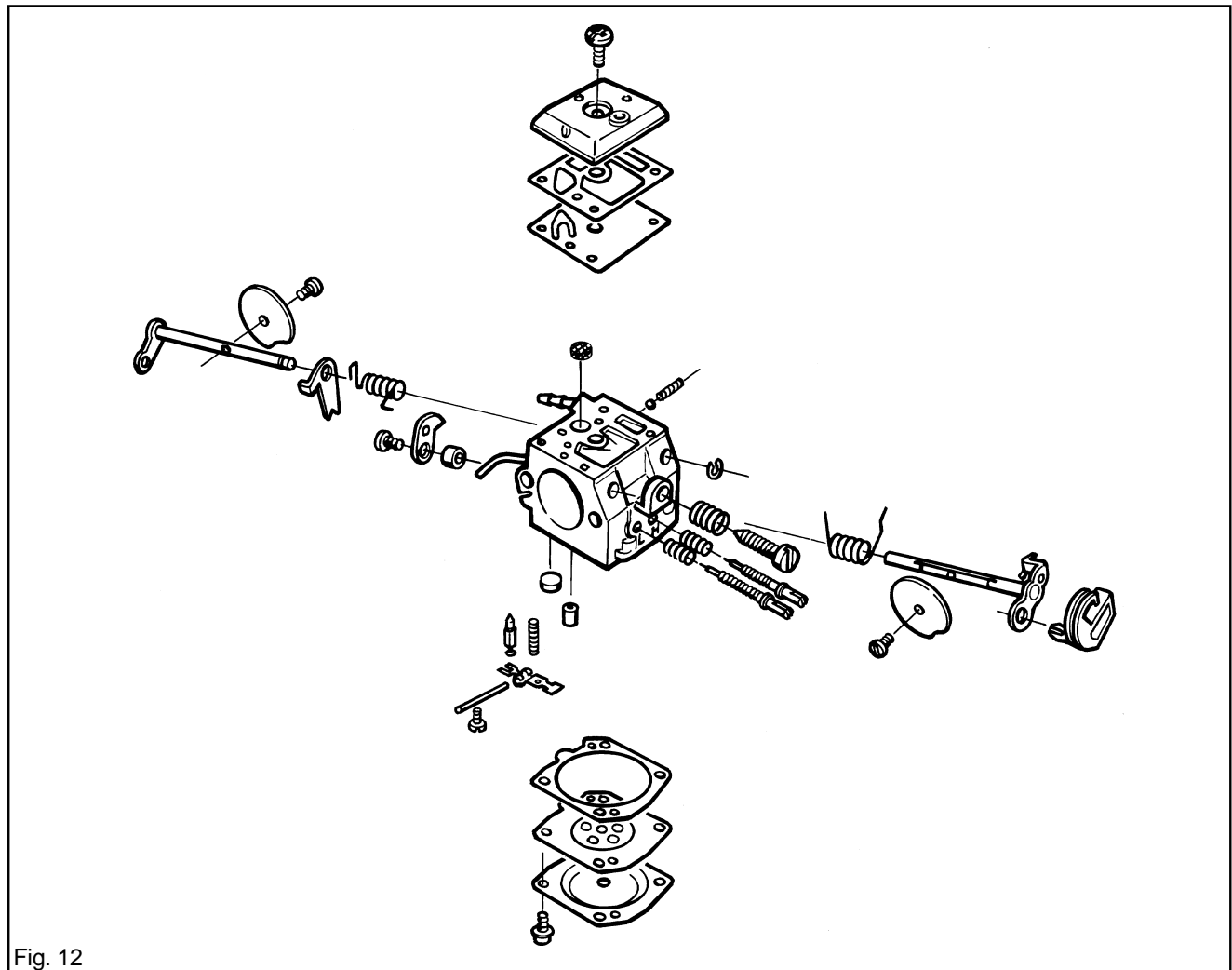

Fig. 12

CARBURETTOR

Reassembly

Where no figure is referred to, see exploded diagram 12 on the previous page.

Assembly

Complete cleanliness is essential when reassembling the carburettor. The smallest dirt particle can cause running problems.

1. If the throttle and choke butterflies, together with their spindles, lever arms and springs were removed, these should be refitted. Lubricate the spindle bearings with light oil.
2. Refit the high and low speed jet screws and springs. Note! Never tighten down the screws. This can damage the seats and needle tips.
3. Position the fuel filter (L) with the help of the handle of a small screwdriver. See fig. 13.
4. Fit the pump diaphragm (K), gasket (J) and cover (I) of the pump unit. See fig. 13.
5. Fit the needle valve (H) with lever arm, spindle and spring and tighten the screw (G). See fig. 14.
6. Check with a ruler or similar that the lever arm is level with the cover face. See fig. 15. If necessary, the lever arm can be bent slightly.
7. Fit the metering diaphragm (F) with gasket and refit the cover (E) of the metering unit. See fig. 16.
8. Carry out pressure testing. See next page.

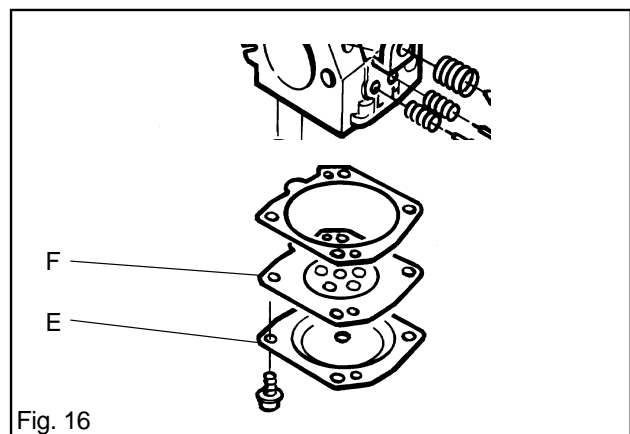
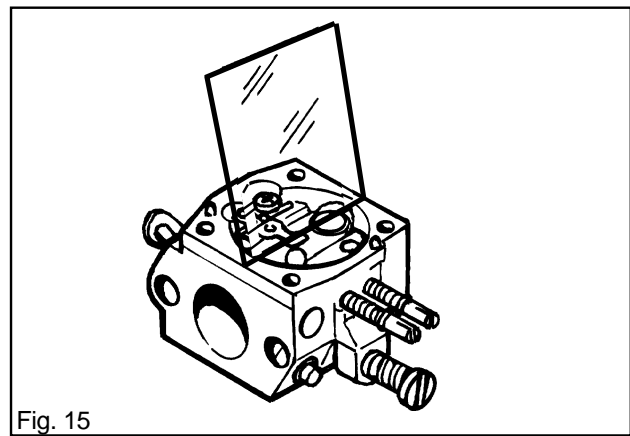
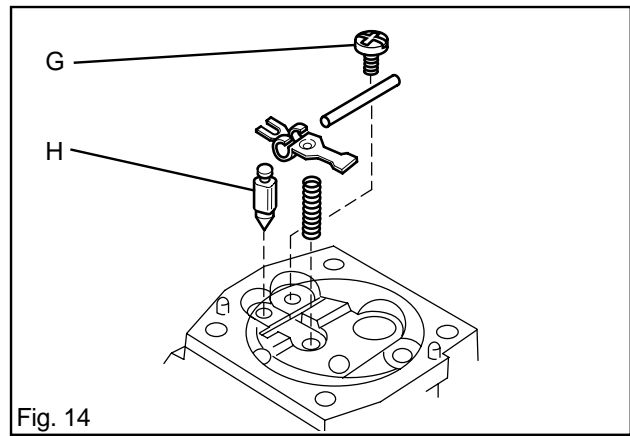
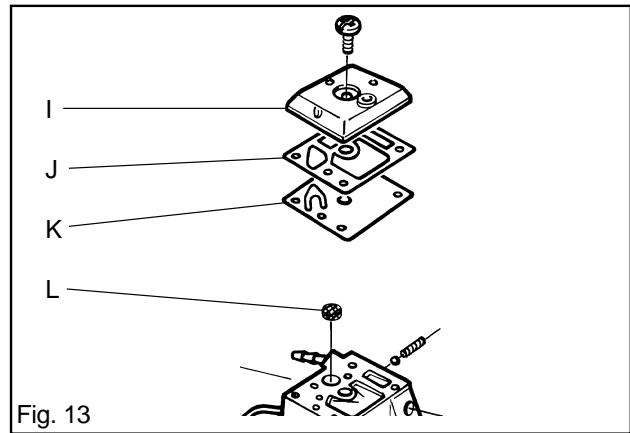

CARBURETTOR

Pressure testing

Pressure testing should be carried out with the carburettor fully assembled. Testing should always be carried out after the carburettor has been repaired, but can also be performed for trouble shooting before dismantling.

Refer to fig. 17 and carry out the test as follows:

1. Screw in the high and low speed jet screws and back them off one turn.
2. Connect pressure tester 502 50 38-01 to the carburettor fuel inlet.
3. Lower the carburettor into a beaker of water.
4. Pump up the pressure to 50 kPa (0.5 bar) and clamp the pump tube.
5. There should be no leakage. If leakage occurs, refer to the table below.

Leakage at	Fault with
Diffuser jets Leakage in impulse tube Ventilation hole above metering unit	Needle valve Pump diaphragm Control diaphragm

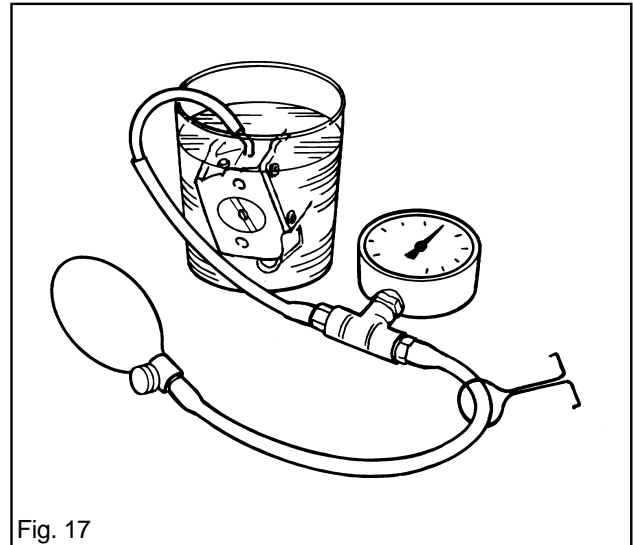

Refitting to the chainsaw

See fig. 18.

1. Loosen the air filter holder and position the carburettor in place in the saw.
2. Bolt together the filter holder, carburettor and air intake tube. Tighten the bolts to 1.5 Nm.
3. Refit the fuel pipe (B) to the fuel nipple and tube (C) to the impulse nipple.
4. Refit the throttle cable and choke control.
5. Refit the carburettor control (A).
6. Refit the cylinder cover and air filter.
See instruction book.

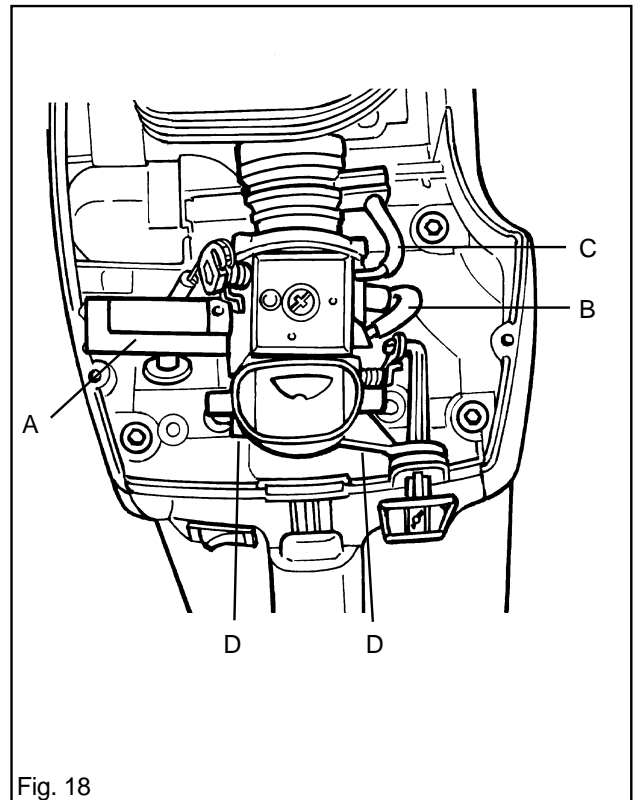

CARBURETTOR

Adjustment



WARNING!
The guide bar, chain and clutch cover must be fitted before the saw is started, otherwise the clutch may come loose causing personal injury.



WARNING!
Wear ear defenders when making adjustments with the motor running.

Adjusting the carburettor involves adjusting the motor to the local conditions e.g. climate, altitude, fuel and type of 2-stroke oil.

The carburettor is equipped with three adjustment options:

- L = Low speed jet
- H = High speed jet
- T = Idling adjustment

The L- and H-jets adjust the fuel flow to match the airflow that the throttle valve opening allows. Turning them clock-wise makes the fuel/air mixture weaker (less fuel) and turning them anti-clockwise makes the fuel/air mixture richer (more fuel). A weaker mixture increases the engine speed and a rich mixture decreases the engine speed.

The T- screw controls the throttle position when idling. Turning the T-screw clockwise gives faster idling, turning it anti-clockwise lower idling speed.

Basic settings and running in

For test running at the factory the basic carburettor settings are used. **The basic settings are H = 1 1/4 and L = 1 1/4 turns respectively.**

In order that motor components receive adequate lubrication (running in) the carburettor should be set to a somewhat richer fuel mixture for the chainsaw's first 3-4 running hours. To achieve this, the max. overspeed is adjusted to 6-700 rpm less than the recommended max. overspeed.

If it is not possible to check the max. overspeed with a tachometer then the H-jet should not be set to a weaker mixture than the basic settings state.

The recommended max. overspeed must not be exceeded. Note! If the chain turns at idling speed, the T-screw should be turned anti-clockwise until the chain stops.

Fine adjustment

When the chainsaw is "run in" fine adjustment of the carburettor should be carried out. Firstly adjust the L-jet screw, then the idling screw T and finally the H-jet screw.

The following are the recommended engine speeds:

	Max. overspeed	Idling speed
362XP:	13 500 rpm	2 700 rpm
365:	12 500 rpm	2 700 rpm
372XP:	13 500 rpm	2 700 rpm

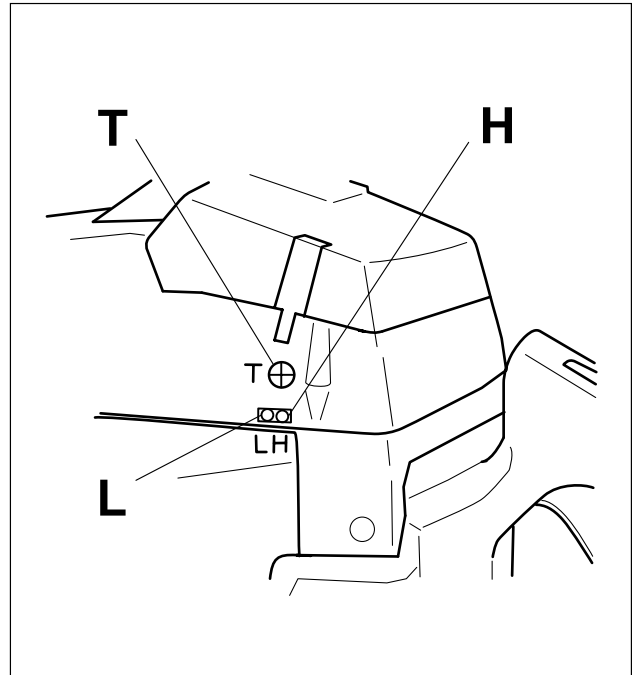

Conditions

During all adjustment, the air filter should be clean and the cylinder cover should be in place. If the carburettor is adjusted with a dirty air filter, the fuel mixture will be too weak next time the air filter is cleaned. This can cause serious engine damage.

Carefully screw in (clockwise) the L- and H-jets fully. Back them off (anti-clockwise) 1 turn. The carburettor now has the settings H = 1 and L = 1.

Start the chainsaw according to the starting instructions and warm up the saw for 10 min.

NOTE! If the chain turns when idling, the T-screw should be turned anti-clockwise until the chain stops.

Place the saw on a flat surface so that the guide bar points away from you and the guide bar is not in contact with the surface or any other object.

CARBURETTOR

Low speed jet L

Find the highest idling speed by slowly turning the L-screw clockwise then anti-clockwise. When the highest speed has been found, turn the L-screw anti-clockwise 1/8 - 1/4 turn.

WARNING! If the chain turns when idling, the T-screw should be turned anti-clockwise until the chain stops.

Fine adjustment of idling T

Setting the idling speed is carried out using the screw marked T. If adjustment is necessary, screw in (clockwise) the idling screw T with the motor running, until the chain starts to turn. Then screw out (anti-clockwise) until the chain stops moving. The correctly set idling speed is when the motor runs smoothly in all positions with a good margin from the speed where the chain starts to move.



WARNING!
Do not use the saw until it has been adjusted so that the chain is still.

High speed jet H

The high speed jet screw H influences the chainsaws power and engine speed. If the H-screw is set too weak (H screw too far in) the saw will over-rev with engine damage as a consequence. Run the saw at full throttle for 10 seconds. Then turn the H-screw anti-clockwise 1/4 turn. Run the saw again at full throttle for 10 seconds and listen to the difference in the max. overspeed. Repeat this procedure again with the H-screw turned a further 1/4 turn anti-clockwise.

You have now run the saw at settings $H \pm 0$, $H = +1/4$ and $H = +1/2$ from the base settings. At full throttle the motor will have sounded different at each setting. The H-screw is correctly adjusted when the saw "burbles" (four-strokes) a little. If the saw "shrieks" then the setting is too weak. If there is a lot of smoke from the exhaust at the same time as the motor burbles then the setting is too rich. Turn the H-screw clockwise to the setting that sounds right.

NOTE!
For optimal setting, a tachometer should be used. The recommended maximum overspeed should not be exceeded.

Correctly adjusted carburettor

A correctly adjusted carburettor means that the saw accelerates without hesitation and the saw burbles a little at full throttle. In addition the chain should not turn when idling. If the L-screw is set too weak this can make the saw difficult to start and cause poor acceleration. If the H-screw is set too weak the saw will have less power, poor acceleration and/or motor damage. An over rich setting of either L or H screws will cause acceleration problems or too low working speed.

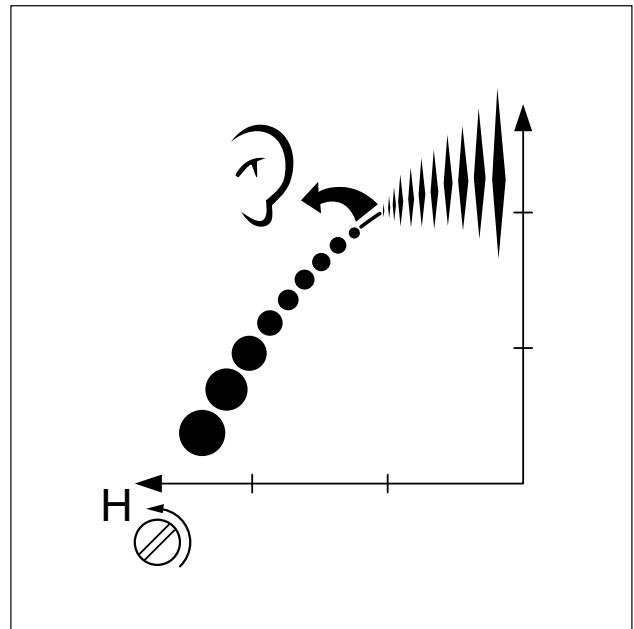
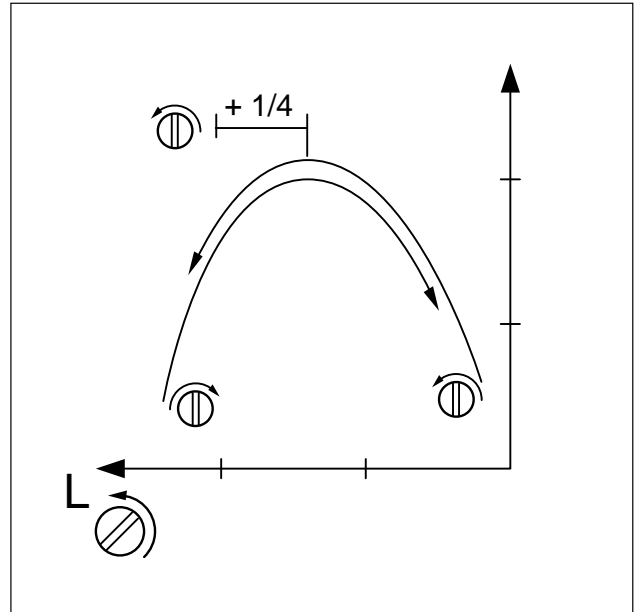

CARBURETTOR

EPA-models

Basic adjustment for EPA carburetors

After replacing the carburettor or high speed and/or low speed needle on an EPA (The US Environmental Protection Agency) certified product a basic adjustment must be carried out as described below in order to meet the EPA-requirements. This to achieve as low emissions as possible. This instruction is made for USA only.

On EPA carburetors both the H and L-jets are fitted with caps to prevent the chain saw operator from changing the adjustment above EPA standard. The caps can be removed to achieve richer or leaner adjustments. To set the jets correctly an *adjustment sleeve* is fitted over the caps to lock them in maximum allowed setting. When correctly set the caps must be fixed on the jets. The adjustment sleeve then can be removed.

NOTE! Before making any adjustments the following must be done!

- Mount, for this model, approved bar & chain combination (See Technical data in the Operator's manual).

Model 362XP	15"
Model 365	18"
Model 372XP	20"

- The chain should not be tensioned more than that it remains ~0,2 inches to the bar.
- Mount a **new** air filter.

Replacement of the H-needle or complete carburettor

1. Screw the new H-needle to the bottom and turn it counterclockwise "A" turns.

Model 362XP	A = 3/4
Model 365	A = 3/4
Model 372XP	A = 3/4

2. **Check that:**

- The H-cap is adjusted to its richest setting. (Turned counterclockwise to stop.)
- The cap is not fixed to the needle, it should rotate independently. Adjust the L-cap to a center position (1/4 turn counterclockwise = minimum, 1/4 turn clockwise = maximum).

3. Start the engine. If necessary, adjust the idling speed with the T-screw until the chain stops.

4. Adjust the H-needle to give a top speed of "B" rpm.

Model 362XP	B = 13 000
Model 365	B = 12 500
Model 372XP	B = 13 500

Use a narrow blade screwdriver (Ref.no. 531 00 48-63) and insert it through the hole in the cap (max. blade width 2 mm/0.08 inch).

5. Let the engine run at 12 500 rpm ~1 minute, until warm.

6. Adjust the H-needle to a top speed of "C" rpm.

Model 362XP	C = 13 500
Model 365	C = 13 000
Model 372XP	C = 14 000

7. Check that the H-cap is still adjusted to its richest setting. (Turned counterclockwise to stop).

NOTE! The H-needle must not rotate!

8. Gently knock the H-cap into position. Use a 5 mm/0.2 inch mandrel (for ex. the locking pin for the bevel gear ref.no. 502 02 61-03).

This is a basic carburettor adjustment. Further fine adjustments, within the limits the caps allow, may be necessary to achieve optimum performance. See the Operator's manual.

Replacement of the L-needle

1. Take off the cap from the L-jet using e.g. a pair of cutting pliers and unscrew the needle.

2. Screw the new L-jet to the bottom and then turn it counterclockwise "D" turns.

Model 362XP	D = 1
* Model 365	D = 1 1/2
Model 372XP	D = 1

* L-jet is not capped and adjustments acc. to 3-9 should not be done.

3. Press a new L-cap on the L-jet to the first stop, which means that the cap is not fixed to the needle, it should rotate independently.

4. Adjust the L-cap to the richest position (turned counterclockwise to stop) without turning the needle.

5. Let the engine run at ~ "E" app. 1 minute until warm and then let it run on idle.

Model 362XP	E = 13 000
Model 372XP	E = 14 000

6. Adjust the idle speed to "F" rpm.

Model 362XP	F = 2 700
Model 372XP	F = 2 700

7. Adjust the L-needle until the highest possible idling speed is achieved and then turn the L-needle 1/2 turn counterclockwise. Use a narrow blade screwdriver w. ref.no. 531 00 48-63 and insert through the hole in the cap (max. blade width 2 mm/0.08 inch)

NOTE! If the chain rotates, turn the idling speed screw (T) counterclockwise until the chain stops.

8. Check that the L-cap is still adjusted to its richest position. (Turned counterclockwise to stop)

NOTE! The L-needle must not rotate!

9. Gently knock the L-cap into position.

Use a 5 mm/0.2 inch mandrel (for ex. the locking pin for the bevel gear ref.no.502 02 61-03).

This is a basic carburettor adjustment. Further fine adjustments, within the limits the caps allow, may be necessary to achieve optimum performance. See the Operator's manual.

TANK UNIT

Tank unit



WARNING!
The fuel that is used in the chainsaw poses the following hazards:
1. The fluid and its fumes are poisonous.
2. Can cause skin irritation.
3. Is highly inflammable.

Dismantling

1. Run off the fuel from the tank.
2. Remove the cylinder cover, chain and guide bar. See instruction book.
3. Disconnect the throttle cable (A) from the carburettor and push out the cable outer from its location. See fig. 1.
4. Remove the fuel pipe (B) from the carburettor.
5. If the saw is equipped with heated hand grips, disconnect the lead at C.
6. Remove the bolts (C and D) and the travel limiter bolt (E) on the clutch side. See fig. 2.
7. Remove the bolt (F) from the flywheel side. See fig. 3.
8. Lift the motor unit slightly and, using pliers, push off the cable clips from their respective switches. If the saw is equipped with hand grip heating, disconnect the leads from on/off switch.

NOTE!
Take care that the fuel pipe and throttle cable are not damaged.

9. Lift the motor unit and turn the tank unit slightly to the flywheel side so that the fixed travel limiter comes free. Lift off the tank unit.
10. If necessary, detach the front hand grip from the tank unit.
11. If necessary, lift out the fuel pipe and pull off the fuel filter. Use tool 502 50 83-01, see item 22, page 7.
12. If the chainsaw is equipped with hand grip heating, detach the connector to the heating element in the rear hand grip. See pages 20 and 21.
13. If the springs are to be removed, refer to AV-system, page 37.

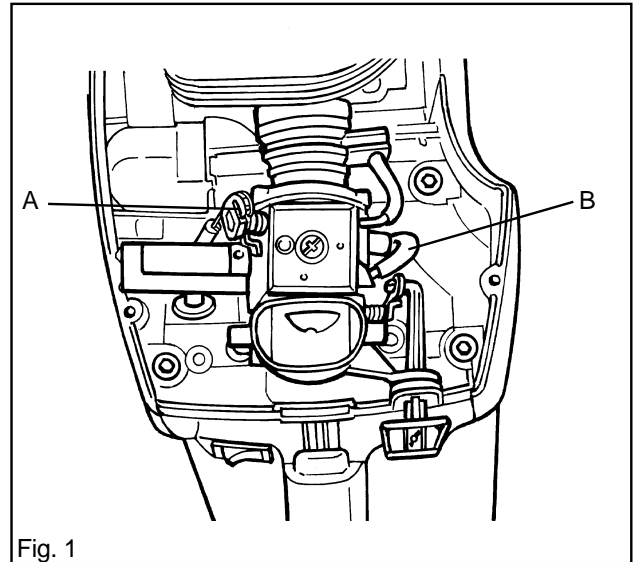

Fig. 1

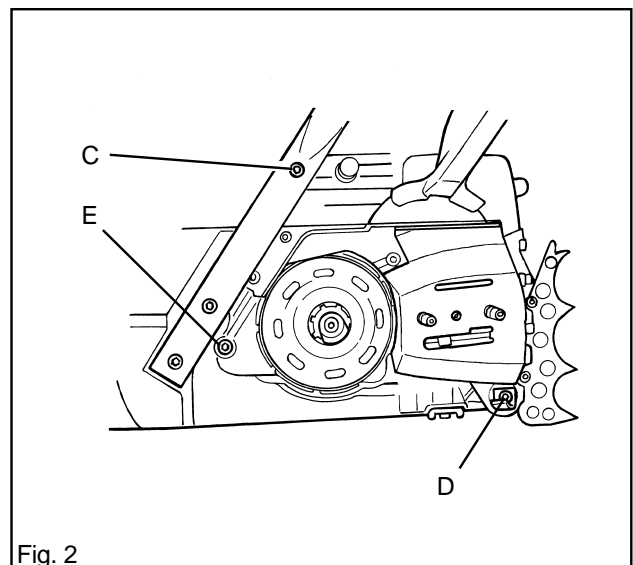

Fig. 2

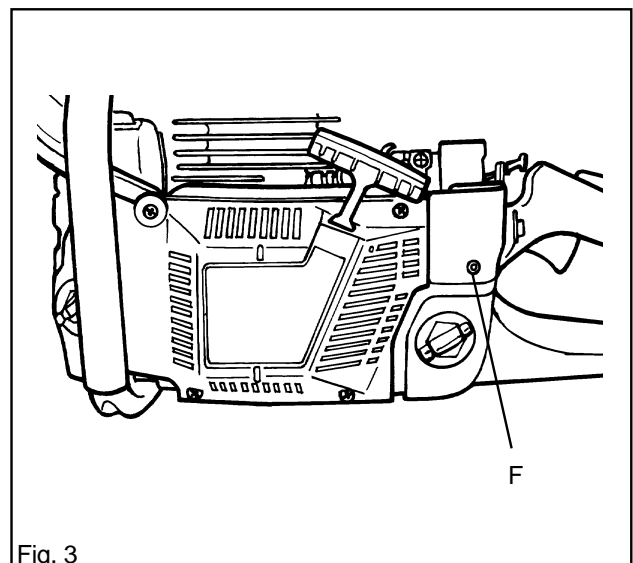

Fig. 3

TANK UNIT

Cleaning and inspection

Clean all components and check that the fuel line is undamaged.

Reassembly

1. If the chainsaw is equipped with hand grip heating, refit the heating element into the rear hand grip, if it has been removed. See pages 20 and 21.
2. If a new fuel hose is to be fitted, proceed as follows:
 - A. Lightly oil in one half of the new fuel hose.
 - B. Thread in the oiled part through the hole in the tank unit. Allow 80-85 mm to protrude on the outside. See fig. 4.
 - C. Twist the hose so that it is bent upwards. See fig. 4.
 - D. Cut off the angled ends of the hose so that it protrudes 70-75 mm on the outside.
 - E. Remove the hose from the tank and fit the fuel filter. Push on the hose as far as it will go.
3. If the front hand grip has been removed, refit it. Tighten the bolts to 4 Nm.

NOTE!
Ensure that the fuel hose and throttle cable are not damaged.

4. If the throttle lock has been removed, it should be refitted before the tank unit and motor unit are reassembled. See page 15.
5. Lift the motor unit over the tank unit and push the fuel line and throttle cable into their holes in the bottom of the carburettor space.
6. Reconnect the leads to the stop switch.
7. Turn the tank unit a little towards the flywheel side so that the fixed travel limiter is in the correct position.
8. Refit the bolt (F) on the flywheel side. See fig. 5. Tighten to 6 Nm.
9. Fit the bolts (C and D), chain catcher and travel limiter bolt (E) on the clutch side. See fig. 6. Tighten the bolts to the torque shown on the diagram.
10. If the saw is equipped with hand grip heating, reconnect the lead at C.
11. Reconnect the fuel line (B) to the carburettor. See fig. 7.
12. Insert the throttle cable outer into its location and reconnect the throttle cable (A) to the carburettor. See fig. 7.
13. Refit the cylinder cover, chain and guide bar. See instruction book.

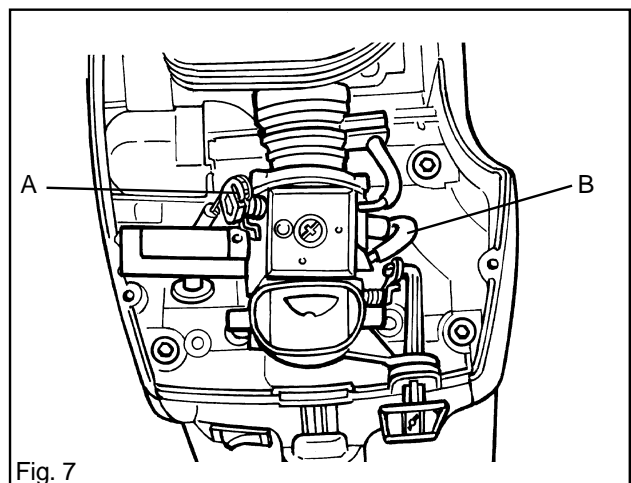
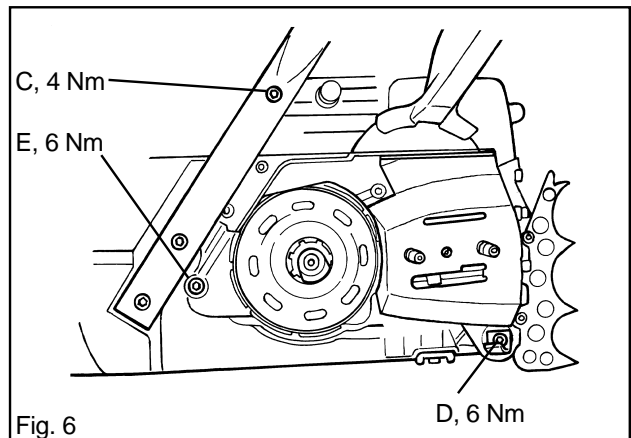
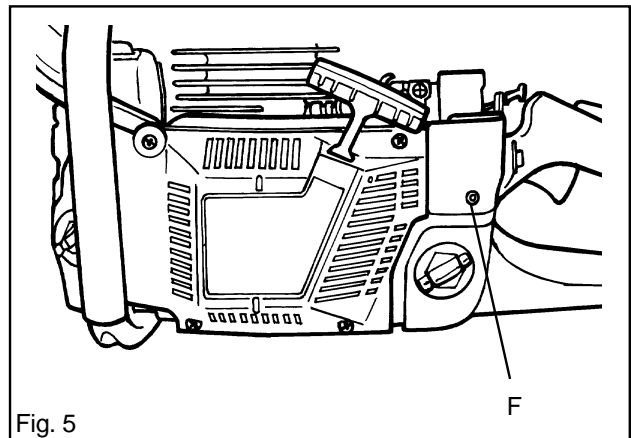
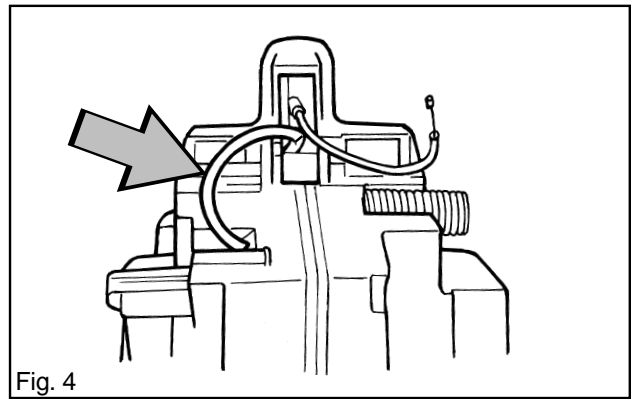

ANTI-VIBRATION SYSTEM

Anti-vibration system



WARNING!
The fuel that is used in the chainsaw poses the following hazards:
1. The fluid and its fumes are poisonous.
2. Can cause skin irritation.
3. Is highly inflammable.

Dismantling

1. Remove the following components:
 - Chain and guide bar. See instruction book.
 - Cylinder cover. See instruction book.
 - Tank unit. See page 35.
2. Detach the springs from the cylinder with the help of a 4 mm Allen key. See fig. 1.
3. Detach the springs from the tank unit with service tools 502 52 18-01 and 502 52 18-02. See fig. 2.

Cleaning and inspection

Clean and inspect all parts.

Reassembly

1. Use pliers to attach the springs to the tank unit.
2. Attach the springs to the cylinder with the help of a 4 mm Allen key. See fig. 1. Tighten the bolts to 10 Nm.
3. Refit the following components:
 - Tank unit. See page 36.
 - Cylinder cover. See instruction book.
 - Chain and guide bar. See instruction book.

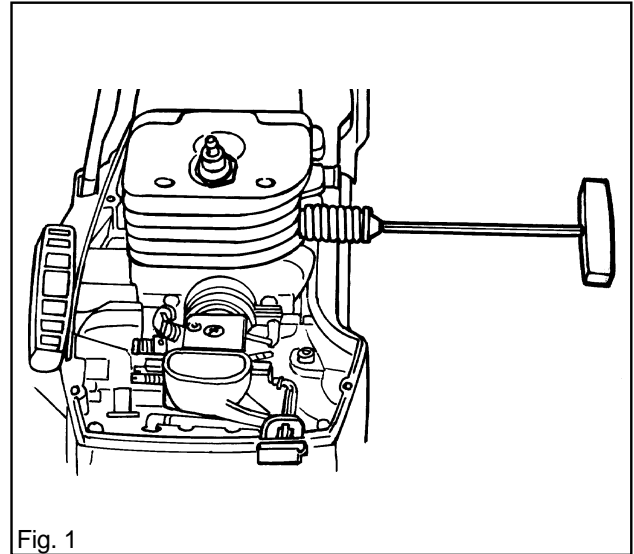

Fig. 1

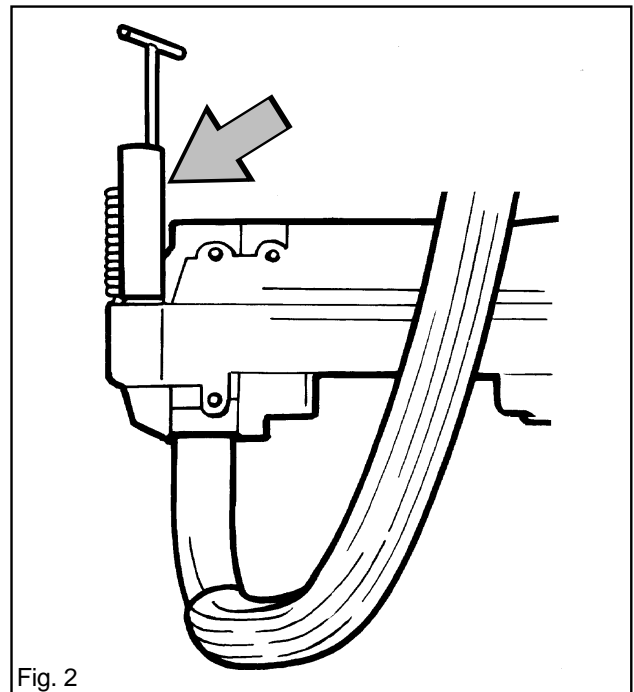

Fig. 2

PISTON AND CYLINDER

Piston and cylinder

Dismantling

1. Remove the following components:
 - Cylinder cover. See instruction book.
 - Spark plug. See instruction book.
 - Carburettor. See page 28.
 - Silencer. See page 14.
2. Remove the impulse hose (A) from the hole on the inlet manifold. See fig. 1.
3. Detach the anti-vibration springs (B) from the cylinder. See fig. 1.
4. Undo the four cylinder retaining bolts (C). See fig. 1.
5. Lift off the cylinder carefully.

NOTE!

Ensure that no dirt or other foreign particles fall into the crankcase.

6. Cover the crankcase opening immediately with paper or clean rag. See fig. 2.
7. Remove one of the piston circlips, press out the gudgeon pin and remove the piston. See fig. 2.
8. Remove the needle roller bearing from the connecting rod little end.
9. Unscrew and remove the decompression valve (D). See fig. 1.
10. Undo the clamp bolt and remove the inlet manifold.

Cleaning and inspection

Clean all components, scrape off the remains of any gasket material and scrape off the carbon deposits from the following surfaces:

1. The piston crown.
2. The top of the cylinder bore.
3. The cylinder exhaust port.
4. The decompression valve channel.

Check the following:

1. The cylinders surface coating is not worn out, especially the upper part of the cylinder. See fig. 3.

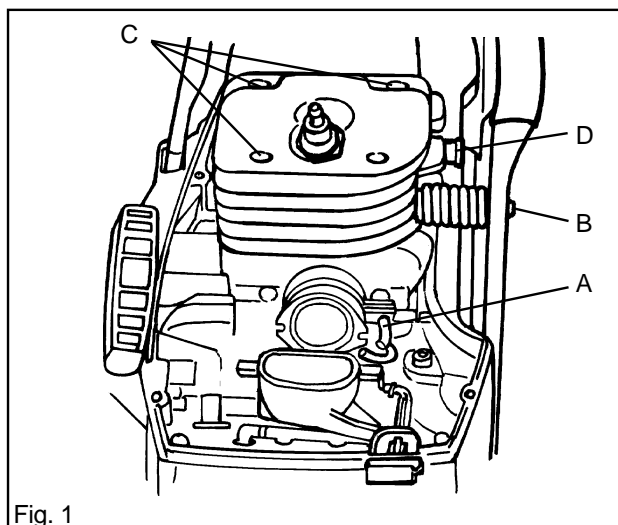

Fig. 1

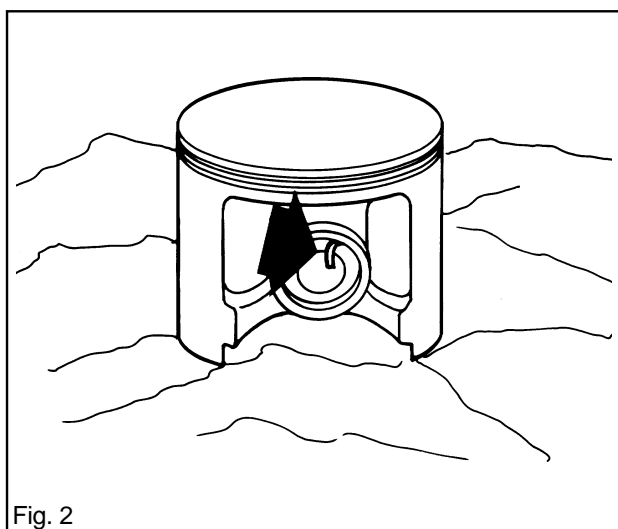

Fig. 2

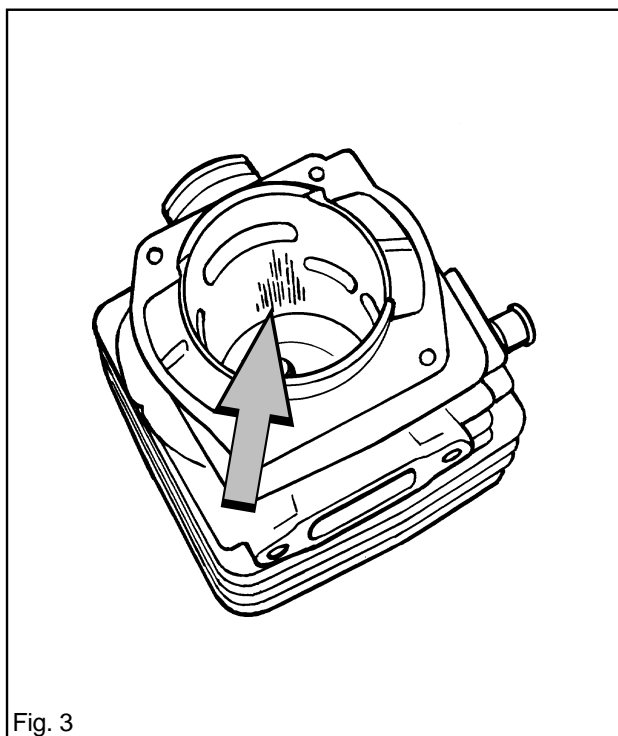
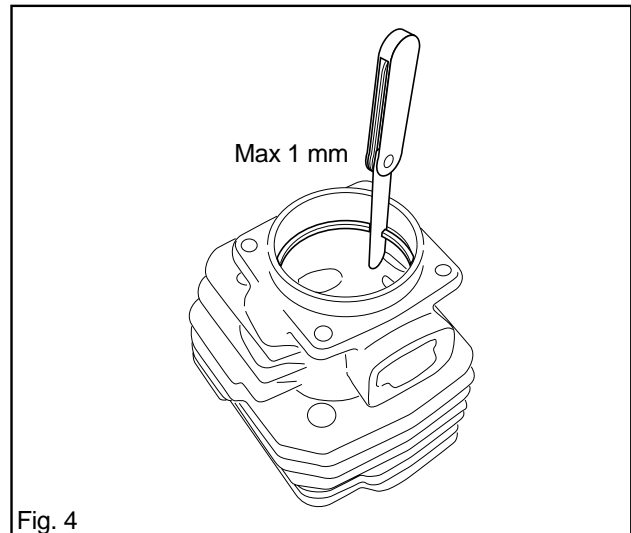

Fig. 3

PISTON AND CYLINDER

2. The cylinder is free of score marks.
3. The piston is free of score marks. Smaller scratches can be polished off with fine emery paper.
4. The piston ring is not burnt into its groove.
5. Measure piston ring wear by placing it in the bottom of the cylinder bore and measuring the gap. See fig. 4. The piston ring gap should not exceed 1 mm.
6. The needle roller bearing is undamaged.
7. The inlet manifold is undamaged.



8. Pressure test the decompression valve as follows. See also fig. 5.
 - A. Connect tool 502 50 38-01 to the decompression valve.
 - B. Pump up the pressure to 80 kPa (0.8 bar).
 - C. Wait 30 seconds.
 - D. The pressure should not be less than 60 kPa (0.6 bar).

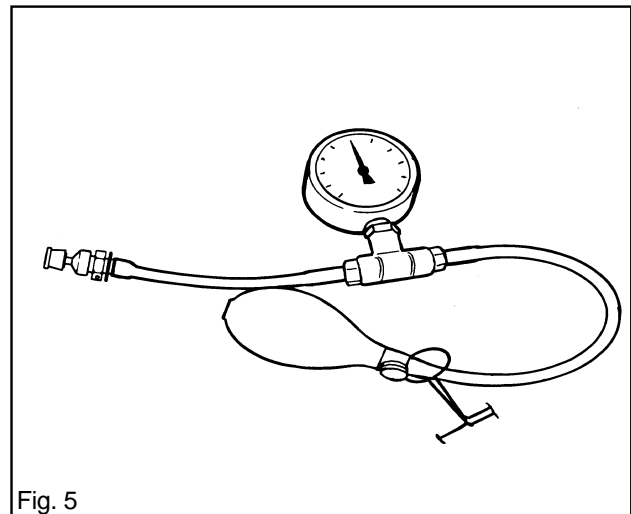

Faults and causes

Score marks on the piston. Fig. 6.

1. Incorrect carburettor settings. Excessive overspeed.
2. Too low octane fuel.
3. Too little or incorrect oil in the fuel.

Carbon build-up. Fig 7.

1. Incorrect carburettor setting. Too low overspeed.
2. Too much or incorrect oil in the fuel.

Piston ring breakage

1. Excessive engine speed.
2. Piston ring worn out.
3. Piston ring groove sloppy.

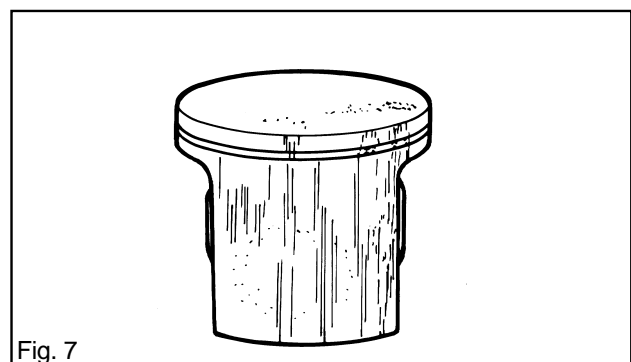
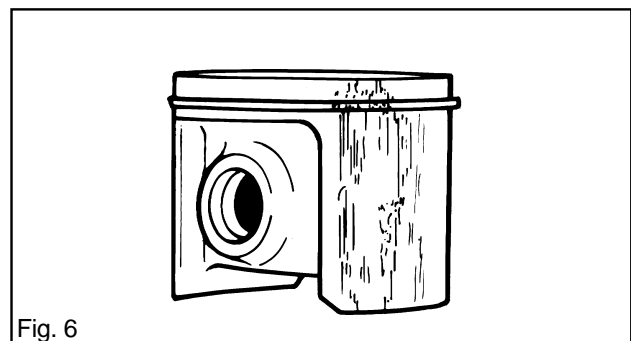

PISTON AND CYLINDER

Reassembly

Carry out assembly of the piston and cylinder as follows:

NOTE!
Ensure that no dirt or other foreign particles fall into the crankcase.

1. Oil in the needle roller bearing and fit it in the connecting rod little end.
2. Locate the piston with the arrow pointing towards the exhaust port. See fig. 8. Press in the gudgeon pin and fit the circlip.
3. Fit the inlet manifold to the cylinder. The clamp bolt should be on the underside. See fig. 9.
4. Locate the gasket on the cylinder base. Push it home so that it fastens on the sleeve of the cylinder.
5. Oil in the piston ring and the sides of the piston.
6. Compress the piston ring either by hand or using the piston ring tool 502 50 70-01. See fig. 10. Carefully fit the cylinder.
7. Fit the four cylinder bolts (C) and tighten them in rotation. Finally, tighten them to 10 Nm. See fig. 11.
8. Refit the decompression valve (D). See fig. 11. Tighten it to 15 Nm.
9. Attach the anti-vibration springs (B) to the cylinder. See fig. 11. Tighten the bolts to 10 Nm.
10. Push home the impulse pipe (A) in the hole on the inlet manifold. See fig. 11.
11. Fit the spark plug and carry out pressure testing according to the instructions on the following page.
12. Refit the following components:
 - Silencer. See page 14.
 - Carburettor. See page 31.
 - Cylinder cover. See instruction book.
13. If a new piston and/or cylinder have been fitted, the saw must be run in for 3-4 hours with the carburettor adjusted to the basic settings (H=1 and L=1). See carburettor settings on pages 32 and 33.

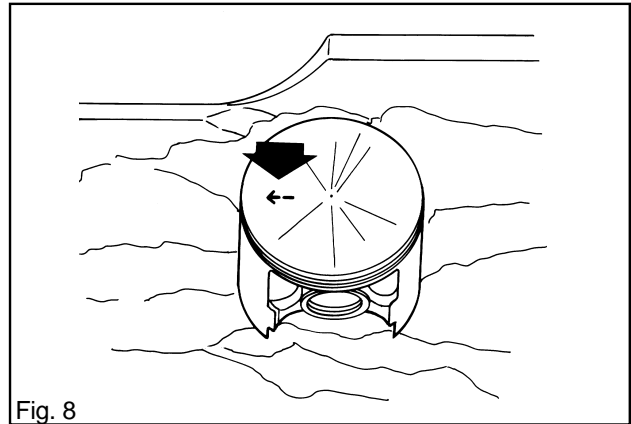

Fig. 8

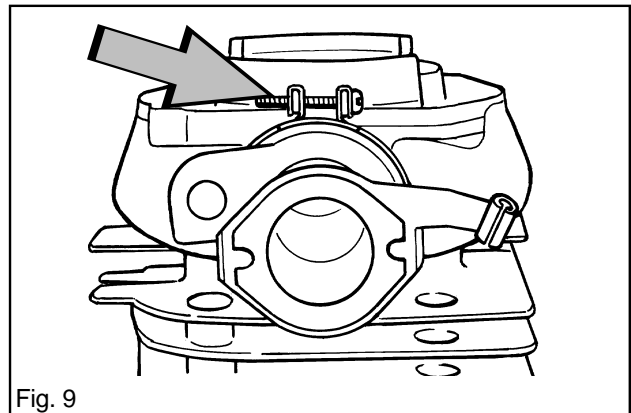

Fig. 9

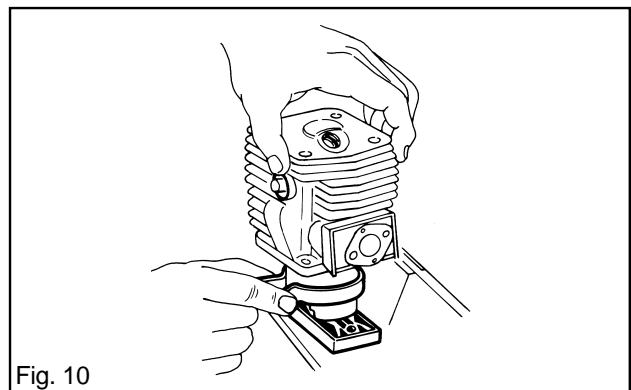

Fig. 10

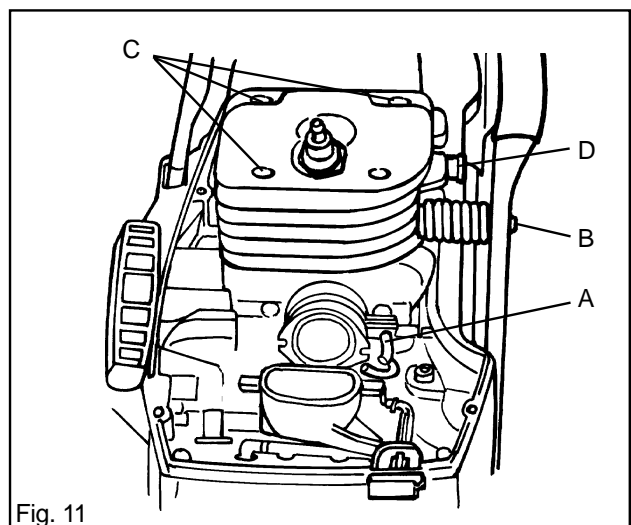

Fig. 11

PISTON AND CYLINDER

Pressure testing

In order to carry out pressure testing on the crankcase and cylinder, the following components should be removed:

- Carburettor. See page 28.
- Silencer. See page 14.

Carry out pressure testing as follows:

1. Fit cover plates 502 54 05-01 and 502 71 39-01 to the inlet manifold and exhaust port. See figs. 12 and 13.
2. Connect tool 502 50 38-01 to the cover plate on the inlet manifold. See fig. 14. The decompression valve should be closed.
3. Close off the pipe to the impulse channel.
4. Pump up the pressure to 80 kPa (0.8 bar).
5. Wait 30 seconds.
6. The pressure should not be less than 60 kPa (0.6 bar).
7. Leakage can occur from the decompression valve and from the crankshaft seals.
8. Refit the following components:
 - Carburettor. See page 31.
 - Silencer. See page 14.

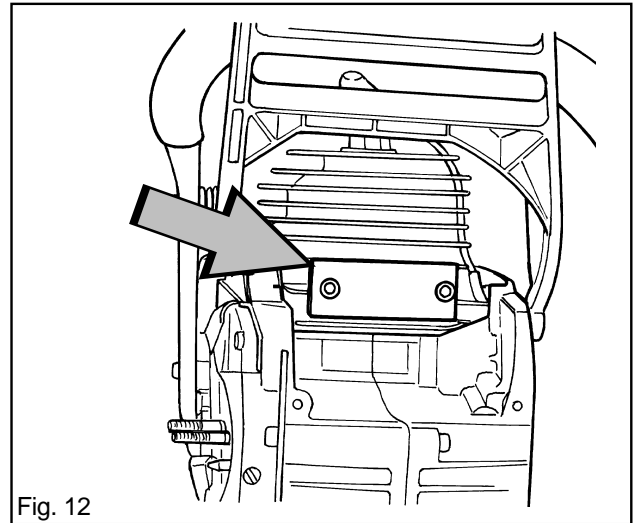

Fig. 12

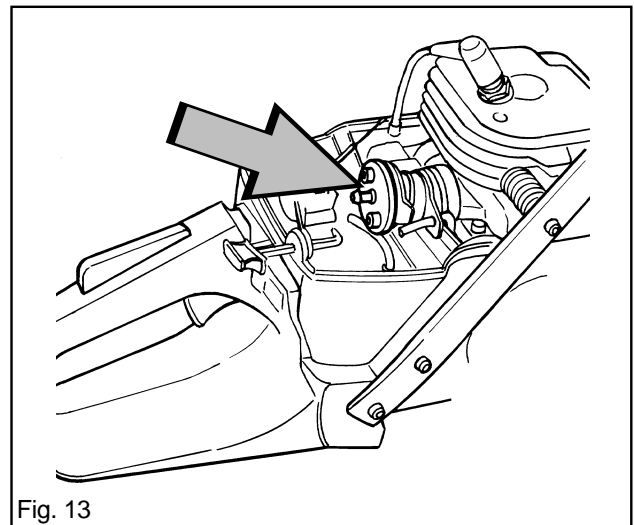

Fig. 13

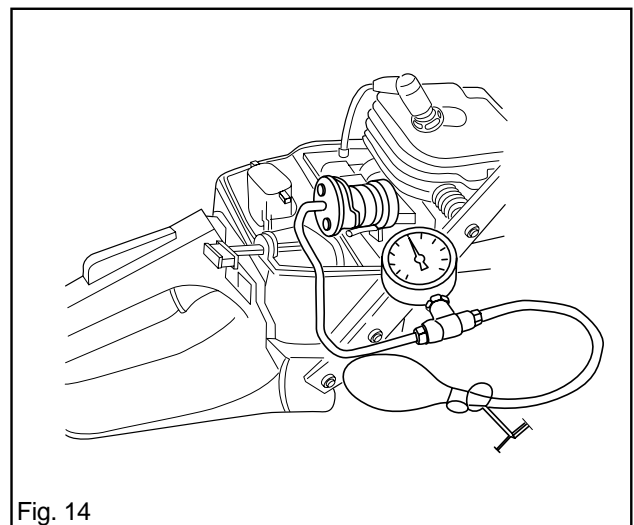

Fig. 14

CRANKCASE AND CRANKSHAFT

This section deals with the following:

- Crankcase and crankshaft (describes how the whole assembly is dismantled and reassembled)
- Seals (describes only replacement of seals)
- Guide bar bolts (describes only replacement of the guide bar bolts)

Crankcase and crankshaft

Dismantling

1. Before the crankcase can be split, the following components must be removed:
 - A. Chain and guide bar. See instruction book.
 - B. Recoil starter. See page 16.
 - C. Electrical system. See pages 18-20.
 - D. Centrifugal clutch. See page 22.
 - E. Lubrication system. See page 22.
 - F. Carburettor. See page 28.
 - G. Silencer. See page 14.
 - H. Piston and cylinder. See page 38.
 - I. Tank unit. See page 35.

NOTE!
Ensure that no dirt or foreign particles enter the bearings.

2. Remove the carburettor space bottom plate by taking out the four bolts.
3. Remove the washer and spacer on the clutch side. See fig. 1.
4. Remove the six bolts on the flywheel side. See fig. 2.
5. Fit tool 502 51 61-01 as shown in fig. 3 and remove the clutch side crankcase half.
6. Remove the flywheel side crankcase half in the same way as for point 5 above.
7. If required remove the seals. Use tools 502 50 55-01 and 504 91 40-01. See fig. 4.

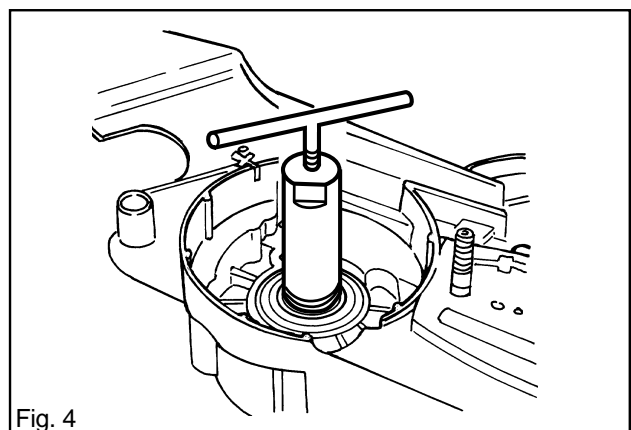
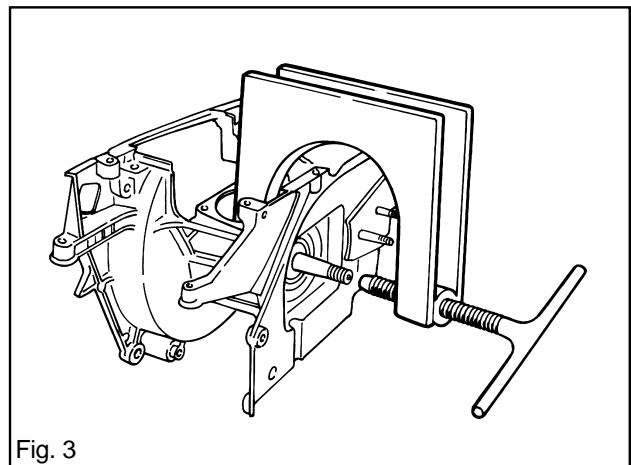
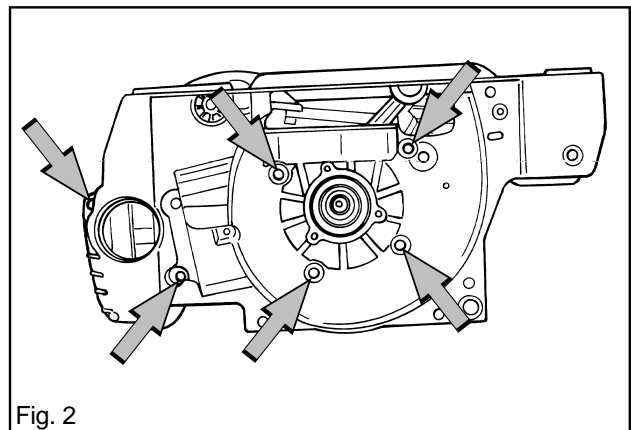
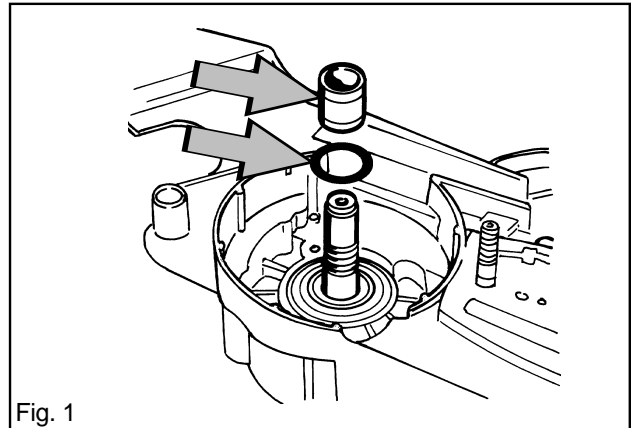

CRANKCASE AND CRANKSHAFT

8. If required, remove the crankshaft bearings from the crankcase. Proceed as follows:



WARNING!
The crankcase halves are hot. Risk for burns. Use protective gloves.

- A. Remove the rubber stop (A). See fig. 5.
 - B. Remove the bush from the chain brake pivot (B). See fig. 6.
 - C. Remove the oil filler cap.
 - D. Warm the relevant crankcase half to 200° C in an oven.
 - E. Using protective gloves take out the crankcase half and tap it gently, with the inside towards a wooden bench or similar, so that the bearing drops out.
 - F. Fit the new bearing into the crankcase whilst it is still hot.
9. Should the bearing have remained in place on the crankshaft, remove it with puller 502 90 90-01.
10. If necessary, remove the following components:
- A. Chain tension screw.
 - B. Guide bar bolts.
 - C. Bark gripper.

Cleaning and inspection

NOTE!
Ensure that no dirt or foreign particles enter the bearings, if they are in place in the crankcase.

Clean all components and scrape off the remains of gasket material from the crankcase half mating surfaces.

Check the following:

1. The big end bearing does not have any radial play. Axial play is acceptable.
2. The big end bearing does not have any score marks or discoloration on the sides. See fig. 7.
3. The little end bearing surface is not scored or discoloured. See fig. 8.
4. The crankshaft bearings do not have any play or dissonance.
5. The sealing surfaces of the crankcase seals on the crankshaft are not worn and that the rubber has not hardened.
6. That the crankcase does not show signs of cracking.

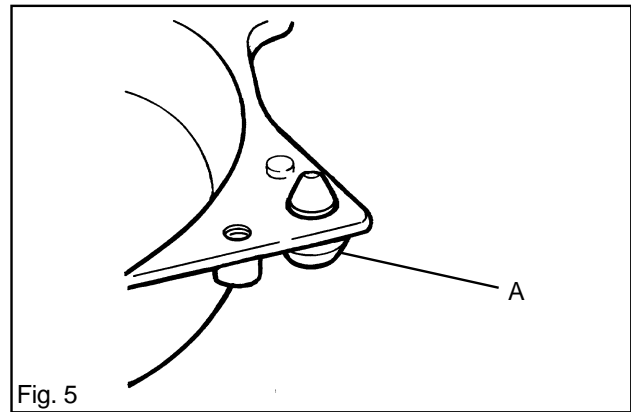

Fig. 5

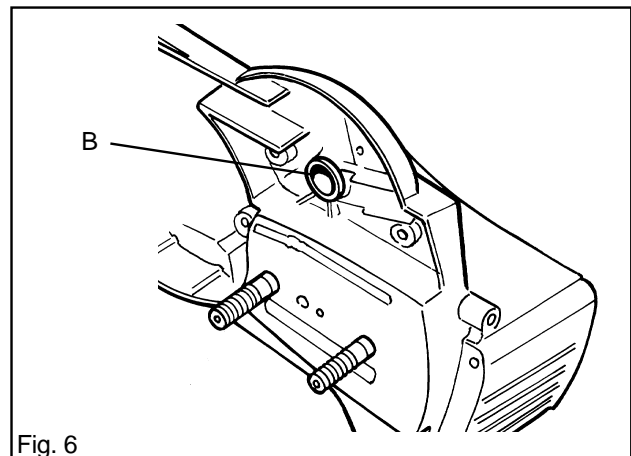

Fig. 6

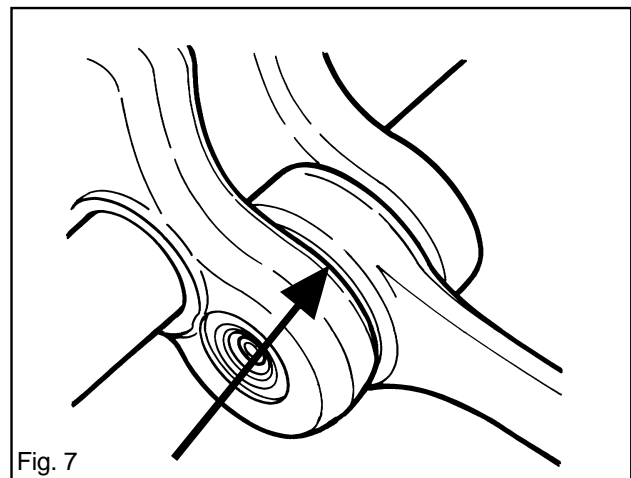

Fig. 7

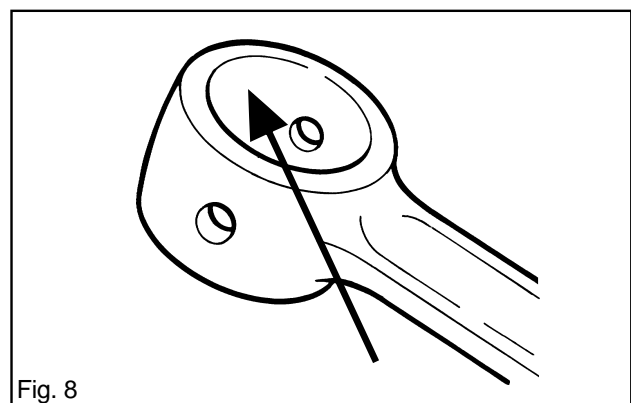

Fig. 8

CRANKCASE AND CRANKSHAFT

Reassembly

Reassemble the crankcase and crankshaft as follows:



WARNING!
The crankcase halves are hot. Risk for burns. Use protective gloves.

1. If bearings are to be fitted, proceed as follows:
 - A. Heat the relevant crankcase half to 200° in an oven.
 - B. Using protective gloves, take out the crankcase half and push home the bearing.
 - C. Let the crankcase cool before continuing work.

NOTE!
Ensure that no dirt or foreign particles enter the bearings.

- D. Refit the rubber stop (A). See fig. 9.
 - E. Refit the oil filler cap.

2. If replacement crankcase seals are to be fitted, grease the seal surfaces and tap them home using tools 502 52 20-01 and 502 52 21-01. See fig. 10.
The seals can also be fitted with the crankshaft in place.

NOTE!
Ensure that the connecting rod does not jam against the crankcase when the crankcase and crankshaft are reassembled.

NOTE!
The crankshaft should be fitted into the clutch half of the crankcase first.

3. Use tool 502 50 30-14 and pull the crankshaft into the clutch half of the crankcase. See fig. 11. Pull until the crankshaft shoulder mates with the bearing.

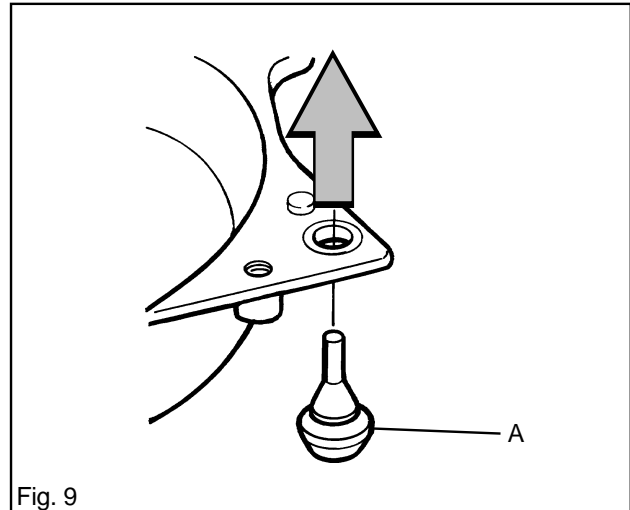

Fig. 9

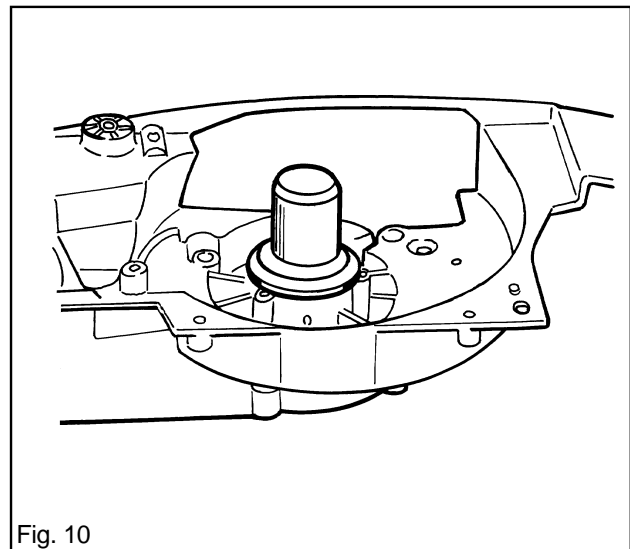

Fig. 10

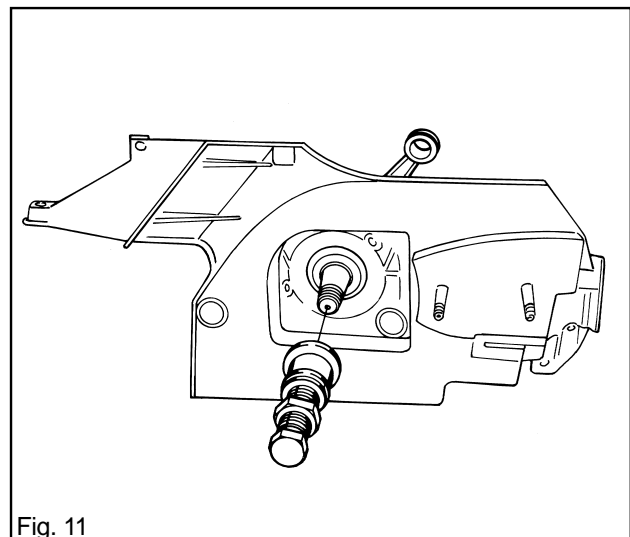

Fig. 11

CRANKCASE AND CRANKSHAFT

4. Locate the guide pegs in the clutch side crankcase half, grease and locate the gasket. See fig. 12.

NOTE!

Continuing to pull with the assembly tool after the gasket is clamped will damage the crankshaft.

5. Use tool 502 50 30-14 and pull on the flywheel side crankcase half. Pull until the gasket is clamped between the two halves. See fig. 13.
6. Insert the six bolts and tighten them in rotation. Tighten them finally to 8 Nm. See fig 14.

NOTE!

Ensure that excess gasket material does not fall into the crankcase.

7. Cut off excess gasket at the level of the cylinder seating plane.
8. Refit the carburettor space bottom plate with the four bolts. Tighten to 5 Nm.
9. Refit the following components:
 - A. Tank unit. See page 36.
 - B. Piston and cylinder. See page 40.
 - C. Silencer. See page 14.
 - D. Carburettor. See page 31.
 - E. Lubrication system. See page 25.
 - F. Centrifugal clutch. See page 23.
 - G. Electrical system. See pages 19-21.
 - H. Recoil starter. See page 17.
 - I. Chain and guide bar. See instruction book.
10. If a new crankshaft has been fitted the saw must be run in for 3-4 hours at the carburettor base settings (H=1 and L=1). See carburettor settings on page 32 and 33.

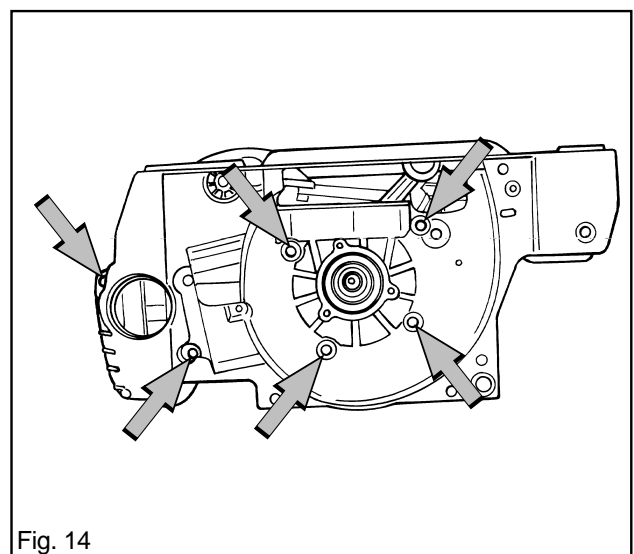
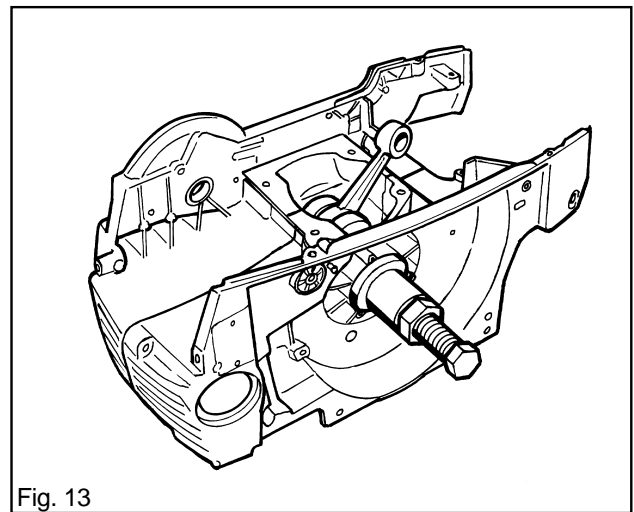
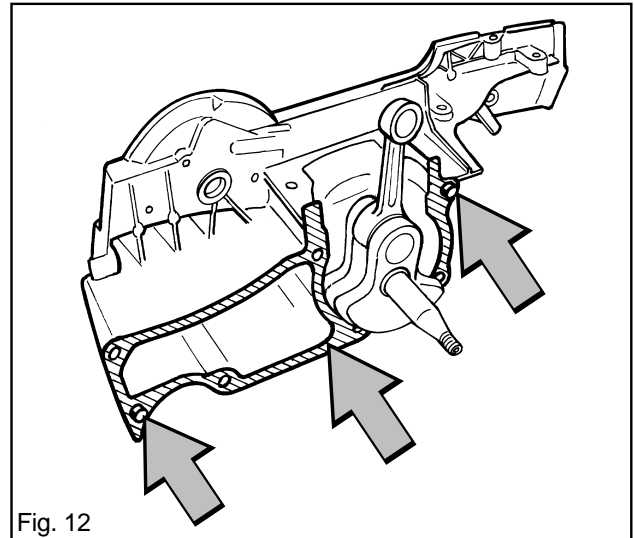

CRANKCASE AND CRANKSHAFT

Crankcase seals

1. To replace the crankcase seals, first remove the following components:

On the flywheel side:

- Recoil starter. See page 16.
- Flywheel. See page 18.
- Generator if fitted. See page 21.

On the clutch side:

- Chain and guide bar. See instruction book.
- Chain guide-plate. See page 12.
- Centrifugal clutch. See page 22.
- Oilpump. See page 24.

2. Screw the appropriate removal tool into the seal and remove it. For correct removal tool, see item 12 or 13 on pages 6 and 7. See also fig. 15.

3. Tap home the new seal with a driver (item 11 on pages 6 and 7). See fig. 16.

4. Refit components listed in point 1 above.

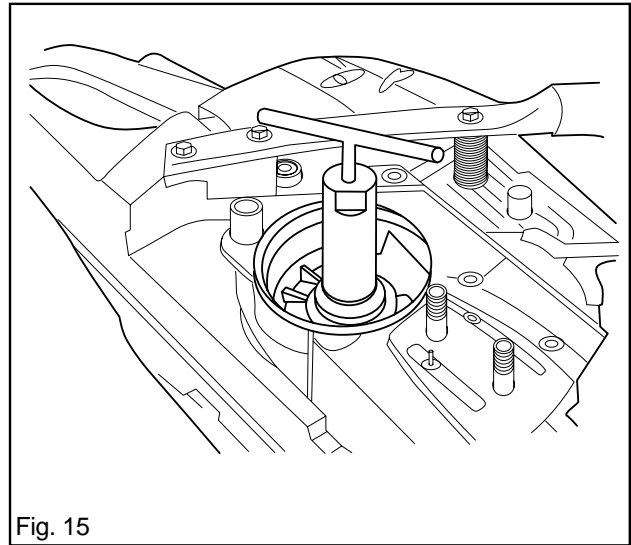

Fig. 15

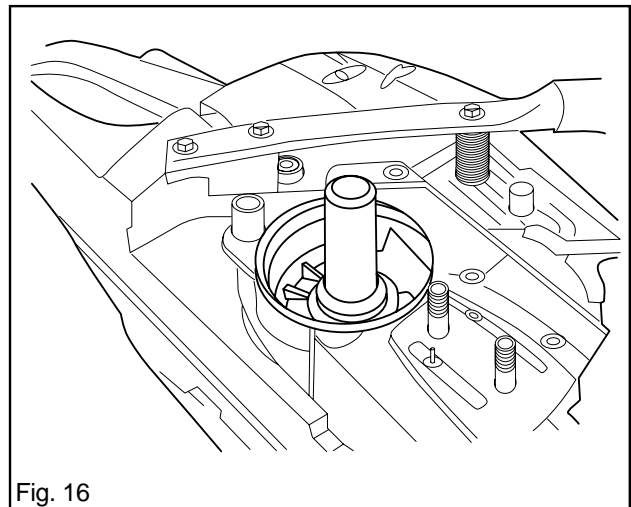

Fig. 16

Guide bar bolts

1. Drain out the chain oil.
2. Knock through the old guide bar bolt so that it falls into the oil tank.
3. Remove the bolt from the oil tank.
4. Fasten a steel wire to the thread of the new bolt, thread the steel wire into the oil tank and out through the bolt hole in the crankcase. See fig. 17.
5. Pull the steel wire until the bolt comes out through its hole.
6. Pull through the bolt with its nut and spacer between the nut and crankcase.
7. Check that the bolts square shoulder is seated in its recess in the crankcase. If necessary, turn the bolt.
8. Refill with chain oil.

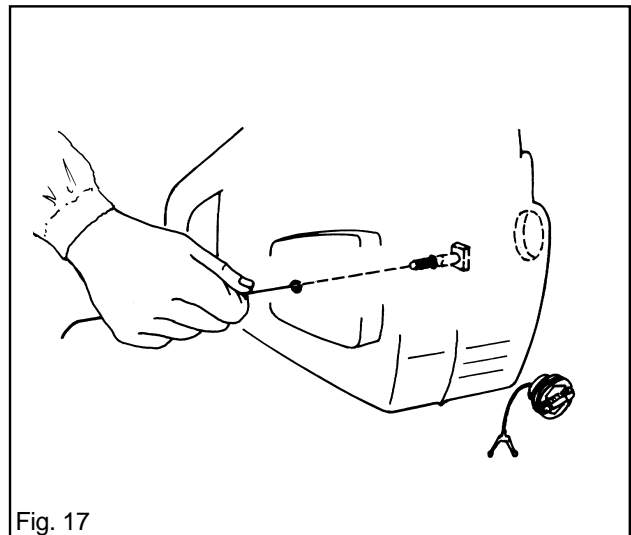

Fig. 17